

ITEM	NO. REQD	PART NO.	PART NAME
①	1	5273548	POWER END ASSEMBLY:
②	1	5260310	FLUID CYLINDER GROUP:
③	1	5273637	ATTACHING GROUP:
④	1	5273629	CYLINDER GROUP:
⑤	2	5257807	PISTON CUP: 1 5/16", CARBOXILATED NITRILE
⑥	1	5266228	LIT KIT:
* ⑦	4	5260142	VALVE SEAT:
* ⑧	4	1219610	CAGE:
* ⑨	4	5253499	DISC & SPRING ASSEMBLY:
* ⑩	2	1219614	VALVE COVER:
* ⑪	6	1177394	O-RING: 1 5/16" OD X 1/8" NOM., BUNA-N
* ⑫	1	1255887	VALVE COVER CLAMP:
* ⑬	1	1100064	HEX HD CAP SCREW: 1/2-13 X 1 1/2" LG.
* ⑭	1	5257095	FLUID CYLINDER:
** ⑮	2	1279148	UMBRELLA: BLACK
** ⑯	2	1269388	UMBRELLA WASHER:
** ⑰	2	1101339	O-RING: 1 1/8" OD X 1/16" NOM., BUNA-N
** ⑱	1	1177200	CAPLUG: INT. 12
** ⑲	1	1177201	CAPLUG: INT. 14
** ⑳	3	1101262	HEX HD CAP SCREW: 3/8-16 X 5" LG.
*** ㉑	4	A91684	CYLINDER GASKET:
*** ㉒	2	1241364	CERAMIC CYLINDER:
*** ㉓	2	1282557	PISTON HOLDER:
*** ㉔	2	5257986	PISTON WASHER:
*** ㉕	2	1284516	HEX HD CAP SCREW: 5/16-18 X 1 1/2" LG.

* THESE COMPONENTS ARE LOCATED IN THE FLUID CYLINDER GROUP, ITEM ②
 ** THESE COMPONENTS ARE LOCATED IN THE ATTACHING GROUP, ITEM ③
 *** THESE COMPONENTS ARE LOCATED IN THE CYLINDER GROUP, ITEM ④

NOTES:

- 1 TORQUE FASTENERS PER FMC ENGR SPEC AS-22
- 2 TEST PUMP PER FMC ENGR SPEC AS-15
- 3 STAMP NAMEPLATE PER FMC ENGR SPEC AS-21
- 4 PAINT PUMP PER FMC ENGR SPEC CP-20

This drawing is the property of FMC Corporation, and may not be used, reproduced, published or disclosed to others without express authorization FMC Corp.		FMC Corporation Fluid Control Division 2825 W. Washington Box 1377 Stephenville, Texas 76401	
Unless Otherwise Specified: Remove all burrs & sharp corners .005 R. All diameters concentric within .010 T.I.R. Angles ±1/2° .X ±.1 .XX ±.015 .XXX ±.005 Finish 125 RMS All dimensions are in inches		PUMP ASSEMBLY A0413C, W/1" NPT X 3/4" NPT FLUID END, CARBOXILATED NITRILE PISTON CUPS & SST DISC VALVE ASSEMBLIES	
RELEASED FOR PRODUCTION	DATE	DRAWN	SCALE: NONE
ECN	DATE	CKD. SL	SIZE
REV	BY	APPD. RMC	DRAWING NO.
K	01-05-81	CHJ	1270230
REVISED & DIGITIZED	ECN	CHJ	03-26-96
WAS	BY	SL	04-09-96
	DATE	RMC	04-15-96

1270230

ITEM	NO. REQD	PART NO.	PART NAME
①	1	5273548	POWER END ASSEMBLY:
②	1	5260310	FLUID CYLINDER GROUP:
③	1	5273637	ATTACHING GROUP:
④	1	5273629	CYLINDER GROUP:
⑤	2	5257807	PISTON CUP: 1 $\frac{5}{8}$ ", CARBOXILATED NITRILE
⑥	1	5266228	LIT KIT:
* ⑦	4	5260142	VALVE SEAT:
* ⑧	4	1219610	CAGE:
* ⑨	4	5253499	DISC & SPRING ASSEMBLY:
* ⑩	2	1219614	VALVE COVER:
* ⑪	6	1177394	O-RING: 1 $\frac{3}{16}$ " OD X $\frac{1}{8}$ " NOM., BUNA-N
* ⑫	1	1255887	VALVE COVER CLAMP:
* ⑬	1	1100064	HEX HD CAP SCREW: $\frac{1}{2}$ -13 X 1 $\frac{1}{2}$ " LG.
* ⑭	1	5257095	FLUID CYLINDER:
** ⑮	2	1279148	UMBRELLA: BLACK
** ⑯	2	1269388	UMBRELLA WASHER:
** ⑰	2	1101339	O-RING: $\frac{1}{16}$ " OD X $\frac{1}{16}$ " NOM., BUNA-N
** ⑱	1	1177200	CAPLUG: INT. 12
** ⑲	1	1177201	CAPLUG: INT. 14
** ⑳	3	1101262	HEX HD CAP SCREW: 3/8-16 X 5" LG.
*** ㉑	4	A91684	CYLINDER GASKET:
*** ㉒	2	1241364	CERAMIC CYLINDER:
*** ㉓	2	1282557	PISTON HOLDER:
*** ㉔	2	5257986	PISTON WASHER:
*** ㉕	2	1284516	HEX HD CAP SCREW: $\frac{5}{16}$ -18 X 1 $\frac{1}{2}$ " LG.

* THESE COMPONENTS ARE LOCATED IN THE FLUID CYLINDER GROUP, ITEM ②

** THESE COMPONENTS ARE LOCATED IN THE ATTACHING GROUP, ITEM ③

*** THESE COMPONENTS ARE LOCATED IN THE CYLINDER GROUP, ITEM ④

PARTS LIST					
CHANGES	ITEM NO	NO REQ'D	DESCRIPTION	PART NUMBER	QTY
	1	2	CROSSHEAD, SLEEVE	1218743	A
	2	2	ASSEMBLY CONNECTING ROD	1263906	B
	3	2	WRIST PIN	1219650	A
	4	1	CASE	1267611	D
	5	1	OIL SLINGER	1255285	B
	6	2	BEARING FAFNIR 205 W	1177804	-
A	7	1	BOLTING STRIP	5241980	A
A	8	2	STOP NUT	1177576	-
	9	2	SEAL GARLOCK 205	1219669	-
	10	2	SNAP RING 5000-206	1113528	-
	11	4	BEARING INSERT	1263739	B
	12	4	HHCS 1/4-20x1 LOCK	1278439	-
	13	1	GASKET, BASE	1219606	B
	14	6	WASHER, WAVE	1177455	-
	15	6	HH CAP SCR 3/8-16x3/4	1100068	-
	16	1	BASE	1255297	B
	17	1	KEY 3/16 x 1-1/2	1108841	-
	18	1	CRANKSHAFT	1244980	C
	19	1	PIPE PLUG 1/4	1109666	-
	20	2	CROSSHEAD	1216823	B
	21	1	PIPE PLUG 3/4 SQ HD GALV	1105060	-
A	22	2	HEX HD CAP SCREW #10-24x 3/4 LG	320502	-
	23	1	NAMEPLATE	5277981	A
	24	2	SELF TAPPING SCREW	1187413	-

△△△
 △△△
 △△△

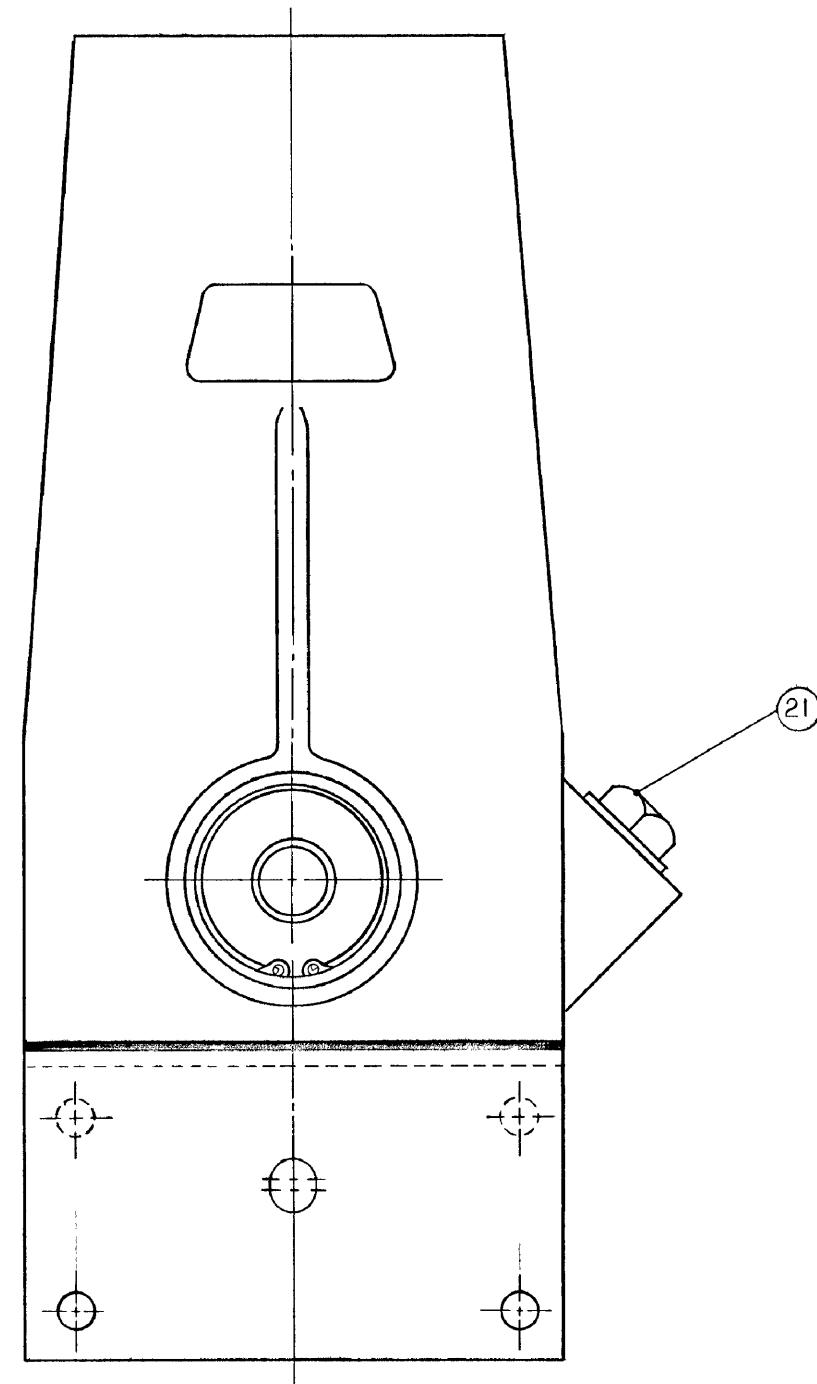
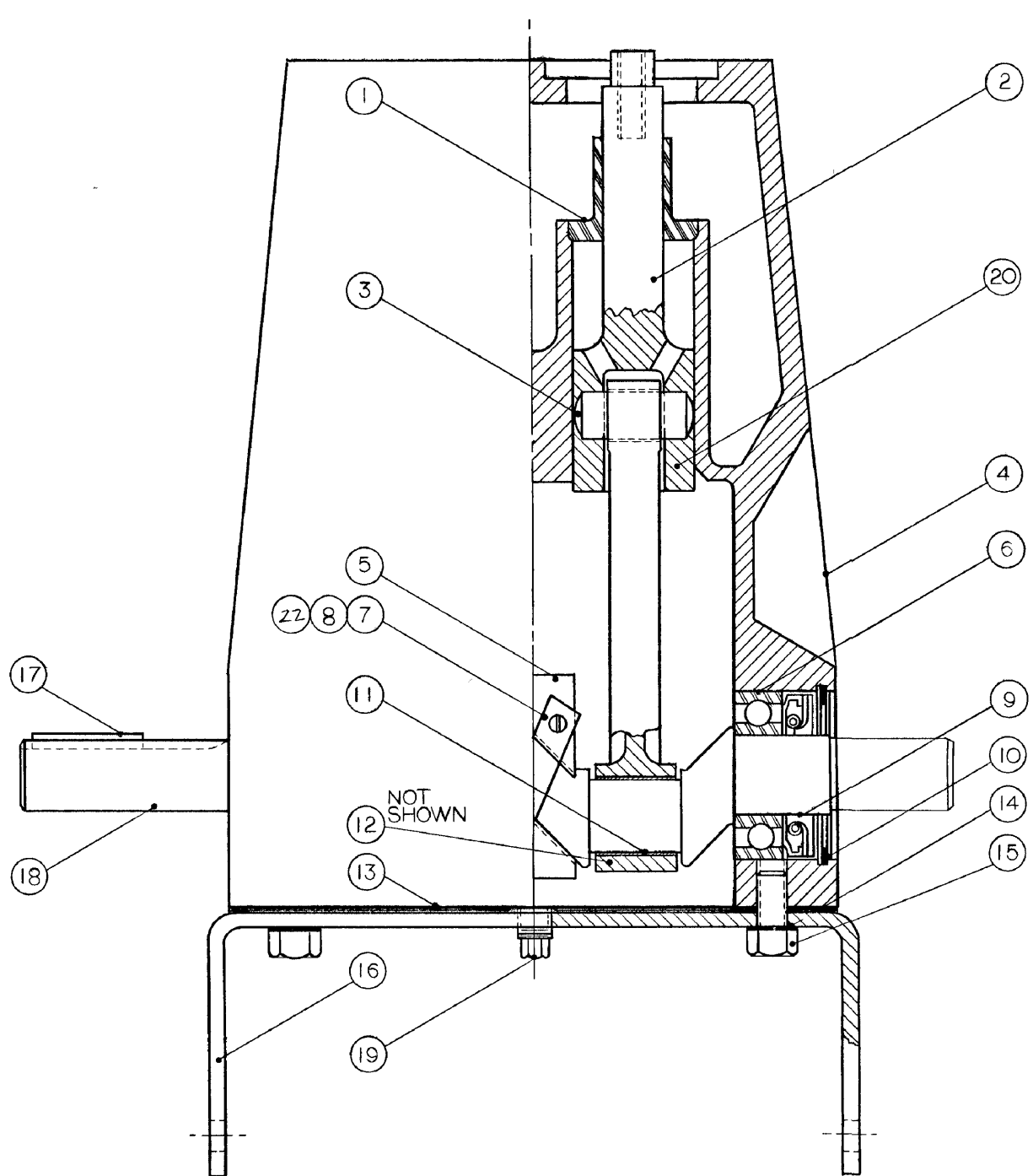

PUMP SPECS:

1. APPLY LIGHT OIL TO CONNECTING ROD BEARINGS, WRIST PINS AND CROSSHEADS (ITEMS 3, 23 & 11).
2. BOLT AND NUT TORQUES:
 CONNECTING ROD BOLTS 6-8 FT LBS.
 MOUNTING BASE BOLTS 15-20 FT LBS.

E REVISED BOM		DRAWN MBE		TOLERANCE ON DIMENSIONS NOT OTHERWISE SPECIFIED		FMC Corporation Agricultural Machinery Division Jonesboro Arkansas	FILE SIZE NC D
D CHANGE ITEM 22		CHECKED		FRACTIONAL DECIMAL ANGULAR			
C REV BOM ITEM 7, 22 + TITLE		APPROVED		DATE 10-5-89		POWER END ASSEMBLY	
B ADDED NAMEPLATE		BY DATE ECN		SCALE NONE		RH DRIVE A04	
A NUMEROUS CHANGES, SEE ECN		REVISIONS		MATERIAL		PART NO	
TOTAL WEIGHT		TOTAL WELD		PAINT SPEC		5273548	
1403080				1403080			

5273548

PARTS LIST

CHANGES			ITEM NO	NO REC'D	DESCRIPTION	PART NUMBER	DWG SIZE	P S ()
			1	2	CROSSHEAD, SLEEVE	1218743	A	
			2	2	ASSEMBLY CONNECTING ROD	1263906	B	
			3	2	WRIST PIN	1219650	A	
			4	1	CASE	1267611	D	
			5	1	OIL SLINGER	1255285	B	
			6	2	BEARING FAFNIR 205 W	1177804	-	
		A	7	1	BOLTING STRIP	5261980	A	
		A	8	2	STOP NUT	1177576	-	
			9	2	SEAL GARLOCK 205	1219669	-	
			10	2	SNAP RING 5000-206	1113528	-	
			11	4	BEARING INSERT	1263739	B	
			12	4	HHCS 1/4-20x1 LOCK	1278439	-	
			13	1	GASKET, BASE	1219606	B	
			14	6	WASHER, WAVE	1177455	-	
			15	6	HH CAP SCR 3/8-16x3/4	1100068	-	
			16	1	BASE	1255297	B	
			17	1	KEY 3/16 x 1-1/2	1108841	-	
			18	1	CRANKSHAFT	1244980	C	
			19	1	PIPE PLUG 1/4	1105666	-	
			20	2	CROSSHEAD	1216823	B	
			21	1	PIPE PLUG 3/4 SQ HD GALV	1105060	-	
		A	22	2	HEX HD CAP SCREW #10-24x 3/4" LG	320502	-	
			23	1	NAMEPLATE	5277981	A	
			24	2	SELF TAPPING SCREW	1187413	-	

