

\* THESE COMPONENTS ARE LOCATED IN THE FLUID CYLINDER ASSEMBLY, ITEM ②  
 \*\* THESE COMPONENTS ARE LOCATED IN THE CYLINDER/PISTON GROUP, ITEM ③  
 \*\*\* THESE COMPONENTS ARE LOCATED IN THE ATTACHING GROUP, ITEM ④

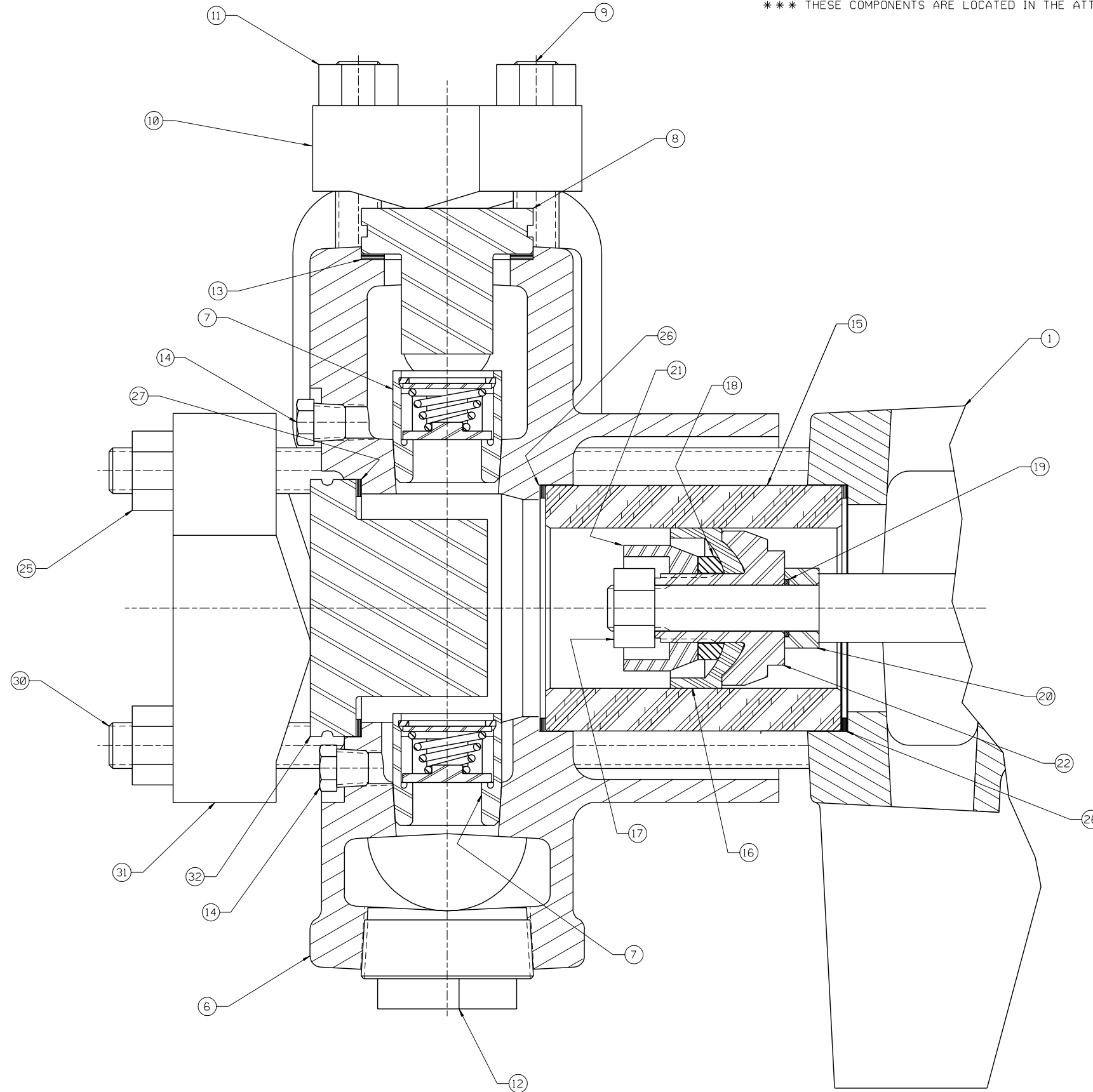

ITEM	NO. RECD	PART NO.	PART NAME
①	1	5271247	POWER END ASSEMBLY: LH
②	1	5271255	FLUID CYLINDER ASSEMBLY:
③	3	5271257	CYLINDER/PISTON GROUP:
④	1	5271263	ATTACHING GROUP:
⑤	1	5271266	MANUAL:
* ⑥	1	1255266	FLUID CYLINDER:
* ⑦	6	1256641	VALVE ASSEMBLY: DISC, 440 SST
* ⑧	3	A5003	VALVE COVER:
* ⑨	6	A5012	STUD: 1/2-13 UNC-2A X 2.81 LG.
* ⑩	3	1271716	VALVE COVER CLAMP:
* ⑪	6	1121511	HEX NUT: 1/2-13
* ⑫	2	1105105	PLUG: 1/2" PIPE
* ⑬	3	1280026	GASKET: VALVE COVER
* ⑭	6	P501267	PLUG: PIPE, 1/8" NPT
△ ** ⑮	3	1245739	CYLINDER: 1.75" ID, CERAMIC
** ⑯	3	1278505	CUP: NEOPRENE
** ⑰	3	8309	HEX NUT: 1/2-13, BRS
** ⑱	3	1278513	WASHER:
** ⑲	3	1101176	O-RING: 3/8" OD X 1/8" NOM., BUNA-N, 70 DURO
** ⑳	3	1284632	SEAL HOLDER:
** ㉑	3	1284624	PACKING NUT:
** ㉒	3	3269025	CUP HOLDER:
*** ㉓	1	1177203	CAPLUG: INT. 20S (NOT SHOWN)
*** ㉔	1	1177201	CAPLUG: INT. 14 (NOT SHOWN)
*** ㉕	8	1121511	HEX NUT: 1/2-13
*** ㉖	6	1280024	GASKET: CYLINDER
*** ㉗	3	1280025	GASKET: CYLINDER COVER
*** ㉘	1	1187039	PETCOCK: (NOT SHOWN)
*** ㉙	2	A5009	STUD: 1/2-13 UNC-2A X 6.63 LG. (NS)
*** ㉚	6	A5011	STUD: 1/2-13 UNC-2A X 8.63 LG.
*** ㉛	3	1271415	CYLINDER HEAD CLAMP:
*** ㉜	3	A5002	CYLINDER COVER:

NOTES:

- 1 TORQUE FASTENERS PER FMC ENGR SPEC AS-22
- 2 TEST PUMP PER FMC ENGR SPEC AS-15
- 3 STAMP NAMEPLATE PER FMC ENGR SPEC AS-21
- 4 PAINT PUMP PER FMC ENGR SPEC CP-20

This drawing is the property of FMC Corporation, and may not be used, reproduced, published, or disclosed to others, without express authorization FMC Corp.	FMC Corporation Fluid Control Division 2825 W. Washington Box 1377 Stephenville, Texas 76481
<b>Unless Otherwise Specified:</b> Remove all burrs & sharp corners .005 R. All diameters concentric unless .001 LSC. Angles ±1/2° .XX ±.015 .XXX ±.005 Finish 125 RMS All dimensions are in inches	<b>PUMP ASSEMBLY</b> F/L0914D, LH, W/1 1/2" NPT X 1" NPT FLUID END, NEOP PACKING, 440 SST DISC VALVE ASSYS

J	REV BOM DESC	508972	DRG	09-01-00	RELEASED FOR PRODUCTION	ECN	DATE	02-29-79	DRAWN	BKM	06-15-98	SCALE:	NONE
I	REV & DIGITIZED	5082204	BKM	06-15-98	CDK.	SJK	06-17-98	SIZE	01	APPD.	JC	06-30-98	DRAWING NO.
REV	WAS	ECN	BY	DATE	✓								1279019

1279019

②  
③

	ITEM	NO. REQD	PART NO.	PART NAME
	①	1	5271247	POWER END ASSEMBLY: LH
	②	1	5271255	FLUID CYLINDER ASSEMBLY:
	③	3	5271257	CYLINDER/PISTON GROUP:
	④	1	5271263	ATTACHING GROUP:
	⑤	1	5271266	MANUAL:
*	⑥	1	1255266	FLUID CYLINDER:
*	⑦	6	1256641	VALVE ASSEMBLY: DISC, 440 SST
*	⑧	3	A5003	VALVE COVER:
*	⑨	6	A5012	STUD: 1/2-13 UNC-2A X 2.81 LG.
*	⑩	3	1271716	VALVE COVER CLAMP:
*	⑪	6	1121511	HEX NUT: 1/2-13
*	⑫	2	1105105	PLUG: 1 1/2" PIPE
*	⑬	3	1280026	GASKET: VALVE COVER
*	⑭	6	P501267	PLUG: PIPE, 1/8" NPT
**	⑮	3	1245739	CYLINDER: 1.75" ID, CERAMIC
**	⑯	3	1278505	CUP: NEOPRENE
**	⑰	3	8309	HEX NUT: 1/2-13, BRS
**	⑱	3	1278513	WASHER:
**	⑲	3	1101176	O-RING: 5/8" OD x 1/16" NOM., BUNA-N, 70 DURO
**	⑳	3	1284632	SEAL HOLDER:
**	㉑	3	1284624	PACKING NUT:
**	㉒	3	3269025	CUP HOLDER:
***	㉓	1	1177203	CAPLUG: INT. 20S (NOT SHOWN)
***	㉔	1	1177201	CAPLUG: INT. 14 (NOT SHOWN)
***	㉕	8	1121511	HEX NUT: 1/2-13
***	㉖	6	1280024	GASKET: CYLINDER
***	㉗	3	1280025	GASKET: CYLINDER COVER
***	㉘	1	1187039	PETCOCK: (NOT SHOWN)
***	㉙	2	A5009	STUD: 1/2-13 UNC-2A X 6.63 LG. (NS)
***	㉚	6	A5011	STUD: 1/2-13 UNC-2A X 8.63 LG.
***	㉛	3	1271415	CYLINDER HEAD CLAMP:
***	㉜	3	A5002	CYLINDER COVER:

△

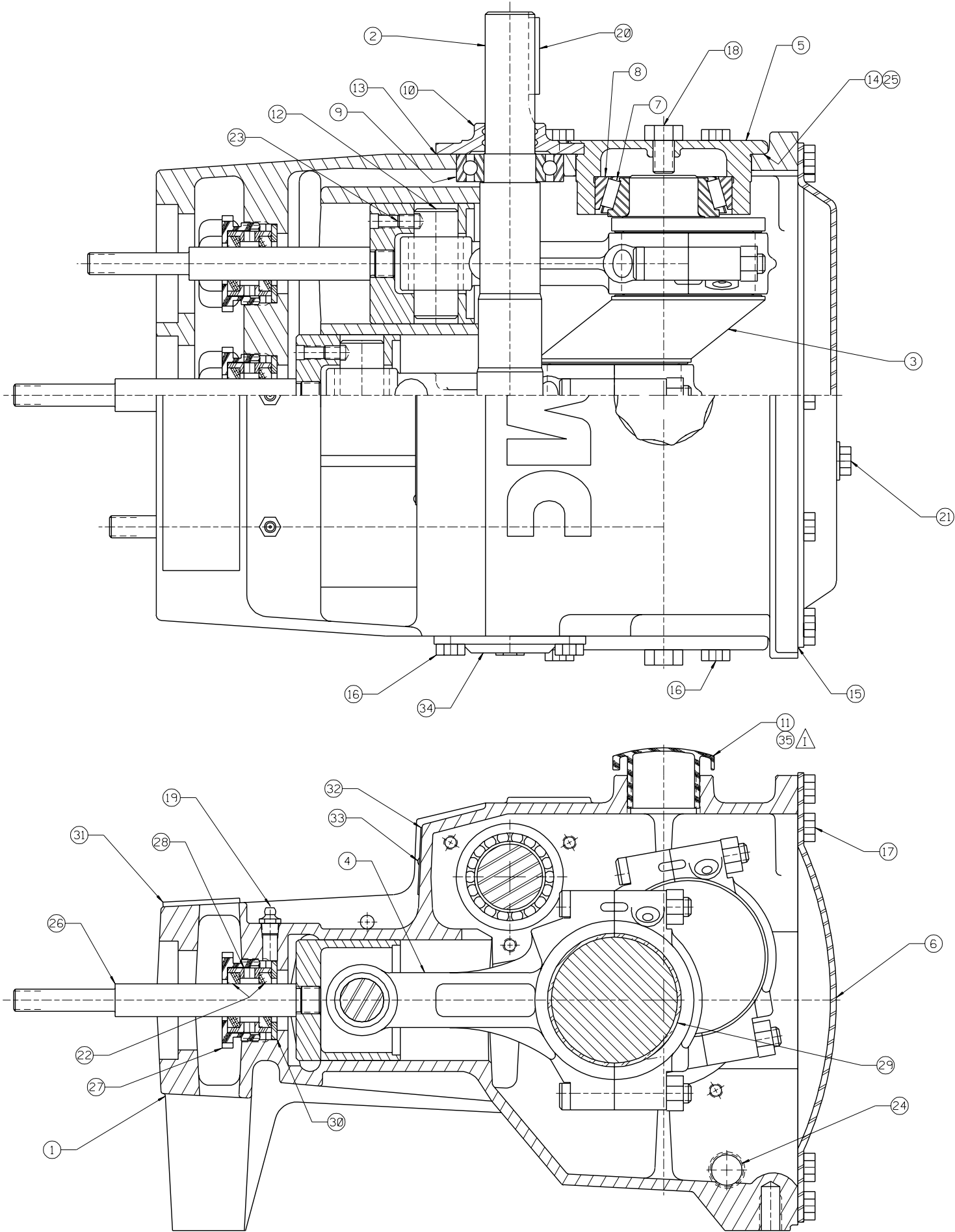

ITEM	NO. RECD	PART NO.	PART NAME
①	1	5260537	POWER FRAME:
②	1	1265098	PINION SHAFT:
③	1	1279071	ECCENTIRC GEAR ASSEMBLY:
④	3	18710	CONNECTING ROD ASSEMBLY:
⑤	2	1279064	ECCENTRIC BEARING CAP:
⑥	1	1279063	BACKCOVER:
⑦	2	1101242	BEARING CONE: 1.56 ID, TIM #26881
⑧	2	1177287	BEARING CUP: 3.125 OD, TIM #26822
⑨	2	1104444	BALL BEARING: 1.18 ID, SINGLE ROW
⑩	1	A5005	PINION BEARING CAP:
⑪	1	A5054	OIL CAP:
⑫	3	A5006	WRIST PIN:
⑬	2	A5026	GASKET: PINION CAP
⑭	2	A5025	GASKET: BEARING CAP
⑮	1	1279065	GASKET: BACKCOVER
⑯	12	1100068	HEX HD. CAP SCREW: 3/8-16 X 3/4" LG.
⑰	14	1106910	HEX HD. CAP SCREW: 3/8-16 X 1/2" LG.
⑱	2	1106980	HEX HD. CAP SCREW: 1/2-13 X 3/4" LG.
⑲	3	1100759	LUBE FITTING:
⑳	1	1187577	KEY: 1/4" SQ. X 1 3/4" LG.
⚠ ㉑	1	3269460	PLUG: PIPE, 1/8" NPT, POLY. (NS)
㉒	6	1283603	OIL SEAL: PLUNGER ROD
㉓	6	1103470	SET SCREW: 5/16-18 X 1/2" LG., SOC. HD.
㉔	2	1187048	PLUG: 1/2" PIPE, MAG.
㉕	5	1252594	SHIM:
㉖	3	1250876	CROSSHEAD ASSEMBLY:
㉗	3	1283600	PACKING NUT:
㉘	3	1283601	SLEEVE:
⚠ ㉙	6	P506697	ROD BEARING
㉚	3	1283602	PACKING WASHER:
㉛	1	1214260	INSPECTION PLATE:
㉜	1	5277981	NAMEPLATE:
㉝	2	1187413	SELF-TAPPING SCREW: #4 X 3/16" LG.
㉞	1	1225769	PINION BEARING CAP: CLOSED
⚠ ㉟	1	3269461	PLUG: PIPE, 1 1/4" NPT, POLY. (NS)

NOTES:  
 1 TORQUE FASTENERS PER FMC ENGR SPEC AS-22  
 ⚠ 2 ITEMS 21 AND 35 TO BE INSTALLED AFTER TESTING BEFORE CLEANING AND PAINTING

This drawing is the property of FMC Corporation, and may not be used, reproduced, published, or disclosed to others, without express authorization FMC Corp.		FMC Corporation Fluid Control Division 2825 W. Washington Box 1377 Stephenville, Texas 76481	
Unless Otherwise Specified: Remove all burrs & sharp corners .005 R. All diameters concentric unless .001 I.D. Angles ±1/2° .X ±.015 .XX ±.015 .XXX ±.005 Finish 125 RMS All dimensions are in inches		POWER END ASSEMBLY F/L09, LH	
J	REVISE BOM	500582	DRG 05-15-00
I	REVISE BOM	500481	BKM 09-29-97
H	REVISED & DIGITIZED	12755	CHJ 03-13-95
REV	WAS	ECN	BY DATE
RELEASED FOR PRODUCTION		DRAWN	CHJ 03-13-95
ECN		DATE	SCALE: NONE
✓		✓	SIZE: DRAWING NO.
✓		APPD.	RMc 03-14-95

ITEM	NO. REQD	PART NO.	PART NAME
(1)	1	5260537	POWER FRAME:
(2)	1	1265098	PINION SHAFT:
(3)	1	1279071	ECCENTIRC GEAR ASSEMBLY:
(4)	3	18710	CONNECTING ROD ASSEMBLY:
(5)	2	1279064	ECCENTRIC BEARING CAP:
(6)	1	1279063	BACKCOVER:
(7)	2	1101242	BEARING CONE: 1.56 ID, TIM #26881
(8)	2	1177287	BEARING CUP: 3.125 OD, TIM #26822
(9)	2	1104444	BALL BEARING: 1.18 ID, SINGLE ROW
(10)	1	A5005	PINION BEARING CAP:
(11)	1	A5054	OIL CAP:
(12)	3	A5006	WRIST PIN:
(13)	2	A5026	GASKET: PINION CAP
(14)	2	A5025	GASKET: BEARING CAP
(15)	1	1279065	GASKET: BACKCOVER
(16)	12	1100068	HEX HD. CAP SCREW: $\frac{3}{8}$ -16 X $\frac{3}{4}$ " LG.
(17)	14	1106910	HEX HD. CAP SCREW: $\frac{3}{8}$ -16 X $\frac{1}{2}$ " LG.
(18)	2	1106980	HEX HD. CAP SCREW: $\frac{1}{2}$ -13 X $\frac{3}{4}$ " LG.
(19)	3	1100759	LUBE FITTING:
(20)	1	1187577	KEY: $\frac{1}{4}$ " SQ. X $1\frac{3}{4}$ " LG.
(21)	1	3269460	PLUG: PIPE, $\frac{1}{8}$ " NPT, POLY (NS)
(22)	6	1283603	OIL SEAL: PLUNGER ROD
(23)	6	1103470	SET SCREW: $\frac{5}{16}$ -18 X $\frac{1}{2}$ " LG., SOC. HD.
(24)	2	1187048	PLUG: $\frac{1}{2}$ " PIPE, MAG.
(25)	5	1252594	SHIM:
(26)	3	1250876	CROSSHEAD ASSEMBLY:
(27)	3	1283600	PACKING NUT:
(28)	3	1283601	SLEEVE:
(29)	6	P506697	ROD BEARING
(30)	3	1283602	PACKING WASHER:
(31)	1	1214260	INSPECTION PLATE:
(32)	1	5277981	NAMEPLATE:
(33)	2	1187413	SELF-TAPPING SCREW: #4 X $\frac{3}{16}$ " LG.
(34)	1	1225769	PINION BEARING CAP: CLOSED
(35)	1	3269461	PLUG: PIPE, $1\frac{1}{4}$ " NPT, POLY, (NS)

△

△

△