

NOTE:
 FILL WITH THREE QUARTS SAE 30 WT. NON-DETERGENT OIL.
 TEST PUMP FOR 15 MINUTES.
 PUMP RUST PREVENTIVE SOLUTION THROUGH VALVE CHAMBER
 DRAIN OIL.
 PURGE VALVE CHAMBER WITH COMPRESSED AIR.
 STAMP NAMEPLATE AS FOLLOWS:

| | | | |
|---|--|--|--|
| FMC | | Bean Pump | |
| Intermittent Rating 9.7 H.P. @ 700 PSI K.W. @ _____ KPa Max. Cap. 20 GPM | | Continuous Rating 8.3 H.P. @ 600 PSI K.W. @ _____ KPa L/Min @ 625 RPM | |
| Part No. _____ | | Serial No. _____ | |
| U.S. Patents _____ | | _____ | |

BOLT AND NUT TORQUES:

- CONNECTING RODS-----40 - 45 FT. #
- BEARING COVER-----30 - 35 FT. #
- CORNER STUDS & CYL-----70 - 80 FT. #
- COVER-----75 - 80 FT. #
- VALVE COVER-----55 FT. #

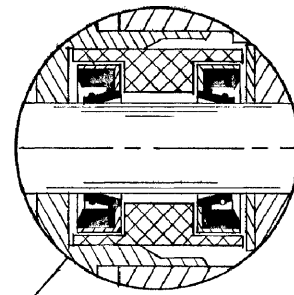
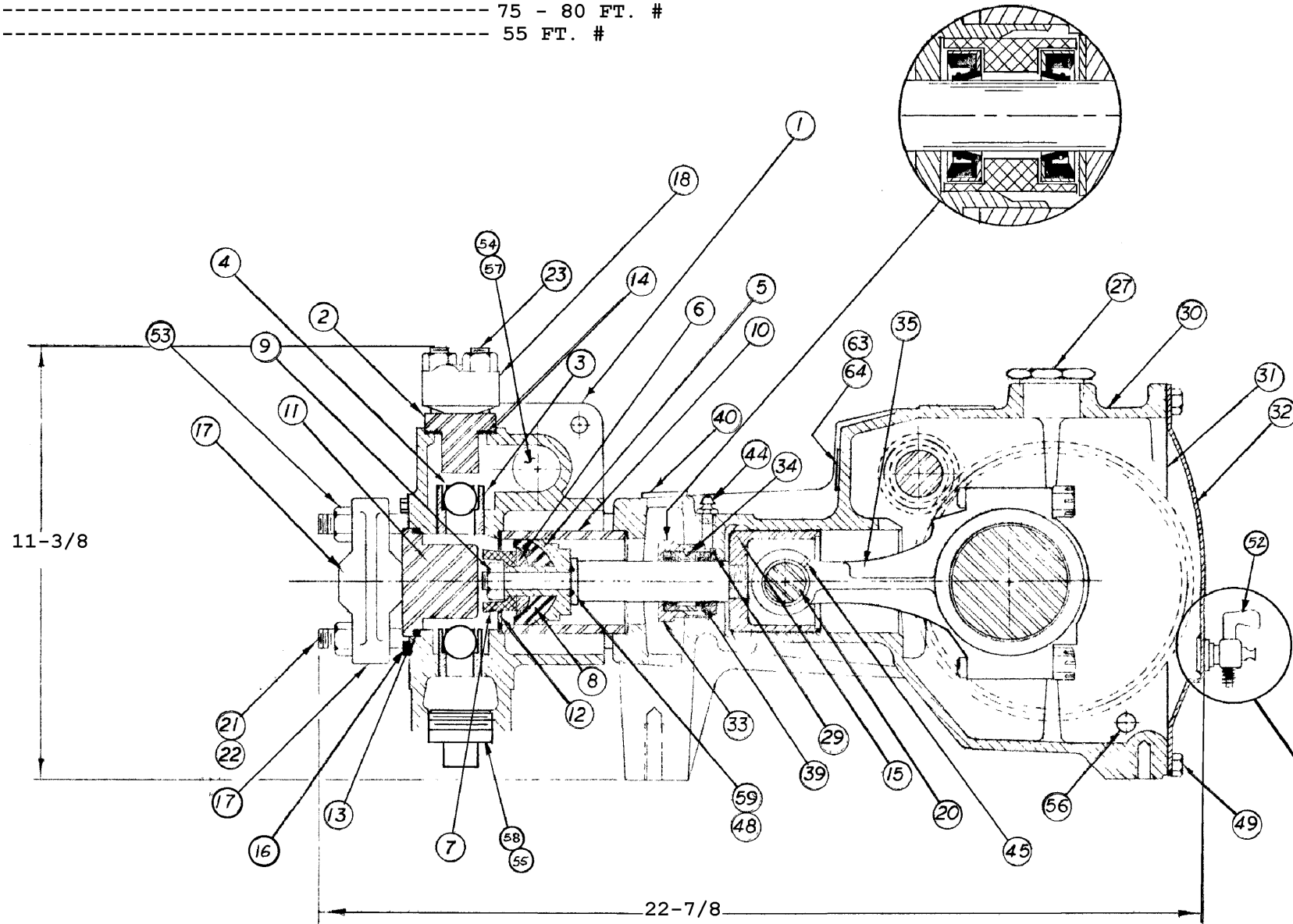

| ITEM NO. | QTY | DESCRIPTION | PART NUMBER | DWG. REV. |
|----------|-----|-------------------------------------|-------------|-----------|
| 35 | 3 | Connect Rod L09 | 18710 | C |
| 36 | 6 | Bearing Eccentric | 19883 | B |
| 37 | 1 | Eccentric & Gear Assembly | 1279071 | B |
| 38 | 1 | Pinion Shaft L09 | 1265098 | B |
| 39 | 6 | Plunger Rod Seal | 1283603 | A |
| 40 | 1 | Cover Plate Assembly | 1214260 | B |
| 41 | 1 | Bearing Cap | 1225769 | A |
| 42 | | | | |
| 43 | 5 | Shims | 1252594 | A |
| 44 | 3 | 1/8 Lube Ftg Str | 1100759 | N |
| 45 | 6 | Set Sc 5/16-18 x 1/2 | 1103470 | N |
| 46 | | | | |
| 47 | 2 | Ball Bearing 1-3/16B | 1104444 | N |
| 48 | 3 | Packing Cup Seal | 1281655 | A |
| 49 | 14 | HHCS 3/8-16 x 1/2 | 1106910 | N |
| 50 | 12 | HHCS 3/8-16 x 3/4 | 1100068 | N |
| 51 | 2 | HHCS 1/2-13 x 3/4 | 1106980 | N |
| G2 | 52 | 1 PETCOCK 1/8 BRASS | 1181939 | N |
| 53 | 14 | Hex Nut 1/2-13 | 1121511 | N |
| G2 | 54 | 1 Caplug Int 14 | 1177201 | N |
| G2 | 55 | 1 Caplug Int 20S | 1177203 | N |
| 56 | 2 | 1/2 Plug Magnetic Sq Hd M-Iron | 1187048 | N |
| G2 | 57 | 1 PIPE 1 PLUG | 1105077 | N |
| G2 | 58 | 2 PIPE 1/2 PLUG | 1105105 | N |
| 59 | 3 | O Ring 5/8 x 1/16 | 1101176 | N |
| G2 | 60 | 1 KEY 1/4 x 1 1/4 | 1187577 | N |
| 61 | 2 | Cone Brg 1-9/16" Tim #26881 Type TS | 1101242 | N |
| 62 | 2 | Cup Bearing 3 125D Tim #26822 | 1277287 | N |
| F | 63 | 1 Nameplate | 5262738 | A |
| 64 | 2 | Screw 4 x 3/16 Tapg | 1187413 | N |

| ITEM NO. | QTY | DESCRIPTION | PART NUMBER | DWG. REV. |
|----------|-----|--------------------------------|-------------|-----------|
| 1 | 1 | Chamber | 1255266 | C |
| 2 | 3 | Valve Cover | A5003 | A |
| 3 | 6 | Valve Seat | A5029 | A |
| 4 | 6 | 15/16" Ball 440 Stn Stl GR-100 | 1187738 | N |
| 5 | 3 | Cup Form | 8495 | A |
| 6 | 3 | Washer | 1207289 | A |
| 7 | 3 | Plunger Nut | A5016 | A |
| 8 | 3 | Cyl Packing 2-1/4" | A3434N | A |
| 9 | 3 | Spec Nut | 8309 | A |
| 10 | 3 | Cyl, 2-1/4 D. Ceramic | 1272060 | A |
| 11 | 3 | Cyl Head | A5002 | A |
| 12 | 6 | Gasket Cyl 420 Pump | 1280024 | A |
| 13 | 3 | Gasket Cyl Hd 420 | 1280025 | A |
| 14 | 3 | Gasket Valve Cover 420 | 1280026 | A |
| 15 | 3 | Crosshead and Rod | 1250876 | B |
| 16 | 6 | PLUG: HEX HD, 1/8" NPT | P501267 | |
| 17 | 3 | Clamp, Cyl Head | 1271415 | A |
| 18 | 3 | Clamp, Valve Cover | 1271716 | A |
| 19 | 1 | Bearing Cap | A5005 | A |
| 20 | 3 | Pin | A5006 | A |
| 21 | 2 | Stud Cyl | A5009 | A |
| 22 | 6 | Cyl Cover Stud | A5011 | A |
| 23 | 6 | Valve Clamp Stud | A5012 | A |
| 24 | 2 | Bearing Housing | 1279064 | B |
| 25 | 2 | Gasket | A5025 | A |
| 26 | 2 | Gasket | A5026 | A |
| 27 | 1 | Oil Cap | A5054 | B |
| 28 | | | | |
| 29 | 3 | Packing Washer L09 | 1283602 | A |
| 30 | 1 | Pump Case L09 | 5260537 | D |
| 31 | 1 | Cover Gasket | 1279065 | A |
| 32 | 1 | Cover Assembly | 1279063 | B |
| 33 | 3 | Packing Nut | 1283600 | A |
| 34 | 3 | Sleeve | 1283601 | A |

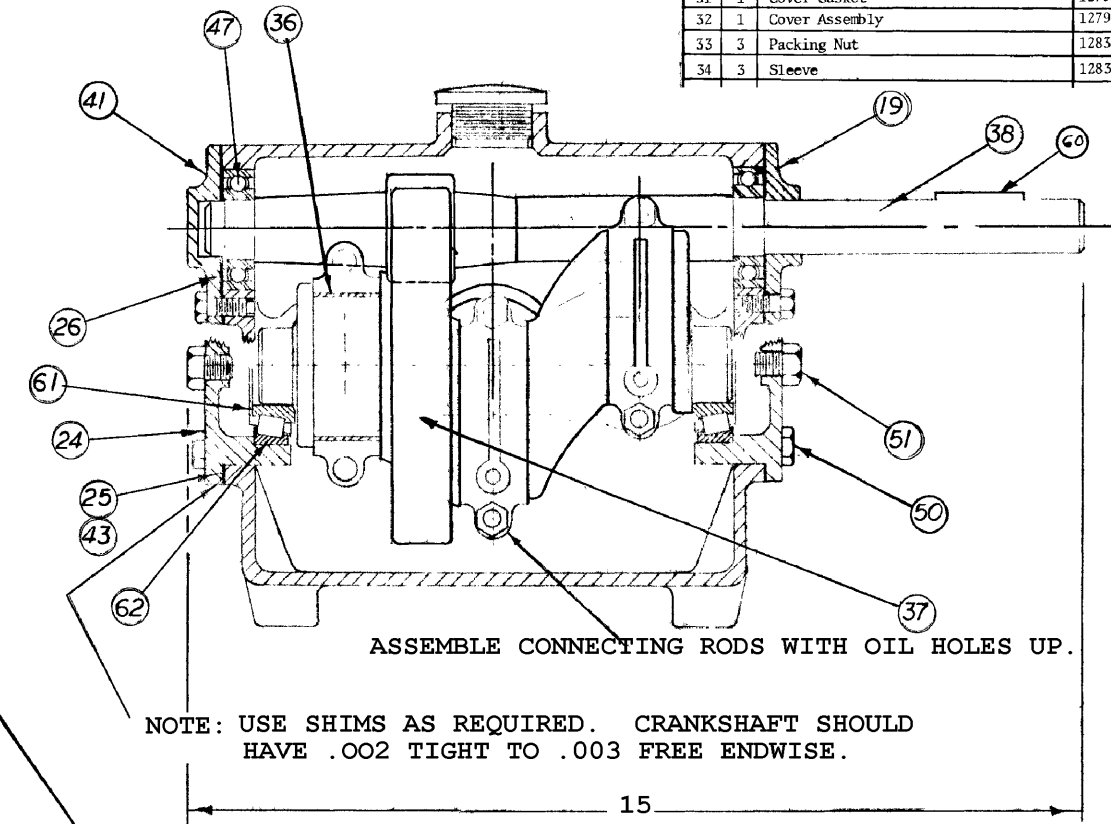

ASSEMBLE CONNECTING RODS WITH OIL HOLES UP.
 NOTE: USE SHIMS AS REQUIRED. CRANKSHAFT SHOULD HAVE .002 TIGHT TO .003 FREE ENDWISE.
 NOTE: WIRE PET COCK TO VALVE CHAMBER STUD BEFORE SHIPPING.

NOTE:
 ITEM (60) SHOULD BE TAPED TO ITEM (38) PINION SHAFT.

| | | | |
|---|-------------------------|-----|---------|
| I | REVISED BOM (5002289) | BOM | 6/15/98 |
| H | MODIFIED BOM'S | SP | 1/22/88 |
| G | NUMEROUS CHANGES | DD | 9/8/82 |
| F | WAS 1276364 | DW | 4-2-81 |
| E | ADDED 5258250 & 1282546 | DW | 2-12-80 |

| | | | | | |
|---|---------|---------|--|----|-------------------|
| TOLERANCE ON DIMENSIONS NOT OTHERWISE SPECIFIED | | | FMC FMC Corporation Agricultural Machinery Division Jonesboro, Arkansas | NC | FILE SIZE D |
| FRACTIONAL | DECIMAL | ANGULAR | | | |
| DRAWN D HALL | | | L0918B-1 | | |
| APPROVED | | | PART NO. 1279027 | | |
| DATE 2-26-79 | | | MATERIAL | | |

| | | | | |
|----|----|-------------------------------------|---------|---|
| 35 | 3 | Connect Rod L09 | 18710 | C |
| 36 | 6 | Bearing Eccentric | 19883 | B |
| 37 | 1 | Eccentric & Gear Assembly | 1279071 | B |
| 38 | 1 | Pinion Shaft L09 | 1265098 | B |
| 39 | 6 | Plunger Rod Seal | 1283603 | A |
| 40 | 1 | Cover Plate Assembly | 1214260 | B |
| 41 | 1 | Bearing Cap | 1225769 | A |
| 42 | | | | |
| 43 | 5 | Shims | 1252594 | A |
| 44 | 3 | 1/8 Lube Ftg Str | 1100759 | N |
| 45 | 6 | Set Sc 5/16-18 x 1/2 | 1103470 | N |
| 46 | | | | |
| 47 | 2 | Ball Bearing 1-3/16B | 1104444 | N |
| 48 | 3 | Packing Cup Seal | 1281655 | A |
| 49 | 14 | HHCS 3/8-16 x 1/2 | 1106910 | N |
| 50 | 12 | HHCS 3/8-16 x 3/4 | 1100068 | N |
| 51 | 2 | HHCS 1/2-13 x 3/4 | 1106980 | N |
| G2 | 52 | 1 PETCOCK 1/8 BRASS | 1181039 | N |
| 53 | 14 | Hex Nut 1/2-13 | 1121511 | N |
| G5 | 54 | 1 Caplug Int 14 | 1177201 | N |
| G6 | 55 | 1 Caplug Int 20S | 1177203 | N |
| 56 | 2 | 1/2 Plug Magnetic Sq Hd M-Iron | 1187048 | N |
| G4 | 57 | 1 PIPE 1 PLUG | 1105077 | N |
| G3 | 58 | 2 PIPE 1 1/2 PLUG | 1105105 | N |
| 59 | 3 | O Ring 5/8 x 1/16 | 1101176 | N |
| G1 | 60 | 1 KEY 1/4 SQ x 1 3/4 | 1187577 | N |
| 61 | 2 | Cone Brg 1-9/16" Tim #26881 Type TS | 1101242 | N |
| 62 | 2 | Cup Bearing 3 12SD Tim #26822 | 1177287 | N |
| F | 63 | 1 Nameplate | 5262738 | A |
| 64 | 2 | Screw 4 x 3/16 Tapg | 1187413 | N |

| CHANGES | | ITEM NO INFO | | DESCRIPTION | PART NUMBER | DWG. SIZE | P S |
|---------|--|--------------|---|--------------------------------|-------------|-----------|-----|
| | | 1 | 1 | Chamber | 1235266 | C | |
| | | 2 | 3 | Valve Cover | A5003 | A | |
| | | 3 | 6 | Valve Seat | A5029 | A | |
| | | 4 | 6 | 15/16" Ball 440 Stn Stl GR-100 | 1187738 | N | |
| | | 5 | 3 | Cup Form | 8495 | N | |
| | | 6 | 3 | Washer | 1207289 | A | |
| | | 7 | 3 | Plunger Nut | A5016 | A | |
| | | 8 | 3 | Cyl Packing 2-1/4" | A3434N | A | |
| | | 9 | 3 | Spec Nut | 8309 | A | |
| | | 10 | 3 | Cyl, 2-1/4 D. Ceramic | 1272060 | A | |
| | | 11 | 3 | Cyl Head | A5002 | A | |
| | | 12 | 6 | Gasket Cyl 420 Pump | 1280024 | A | |
| | | 13 | 3 | Gasket Cyl Hd 420 | 1280025 | A | |
| | | 14 | 3 | Gasket Valve Cover 420 | 1280026 | A | |
| | | 15 | 3 | Crosshead and Rod | 1250876 | B | |
| | | 16 | 6 | PLUG: HEX HD, 1/8" NPT | P501267 | | |
| | | 17 | 3 | Clamp, Cyl Head | 1271415 | A | |
| | | 18 | 3 | Clamp, Valve Cover | 1271716 | A | |
| | | 19 | 1 | Bearing Cap | A5005 | A | |
| | | 20 | 3 | Pin | A5006 | A | |
| | | 21 | 2 | Stud Cyl | A5009 | A | |
| | | 22 | 6 | Cyl Cover Stud | A5011 | A | |
| | | 23 | 6 | Valve Clamp Stud | A5012 | A | |
| | | 24 | 2 | Bearing Housing | 1279064 | B | |
| | | 25 | 2 | Gasket | A5025 | A | |
| | | 26 | 2 | Gasket | A5026 | A | |
| | | 27 | 1 | Oil Cap | A5054 | B | |
| | | 28 | | | | | |
| | | 29 | 3 | Packing Washer L09 | 1283602 | A | |
| | | 30 | 1 | Pump Case L09 | 5260537 | D | |
| | | 31 | 1 | Cover Gasket | 1279065 | A | |
| | | 32 | 1 | Cover Assembly | 1279063 | B | |
| | | 33 | 3 | Packing Nut | 1283600 | A | |
| | | 34 | 3 | Sleeve | 1283601 | A | |

47

36

41