

\* THESE COMPONENTS ARE LOCATED IN THE FLUID CYLINDER ASSEMBLY, ITEM ②  
 \*\* THESE COMPONENTS ARE LOCATED IN THE CYLINDER/PISTON GROUP, ITEM ③  
 \*\*\* THESE COMPONENTS ARE LOCATED IN THE ATTACHING GROUP, ITEM ④

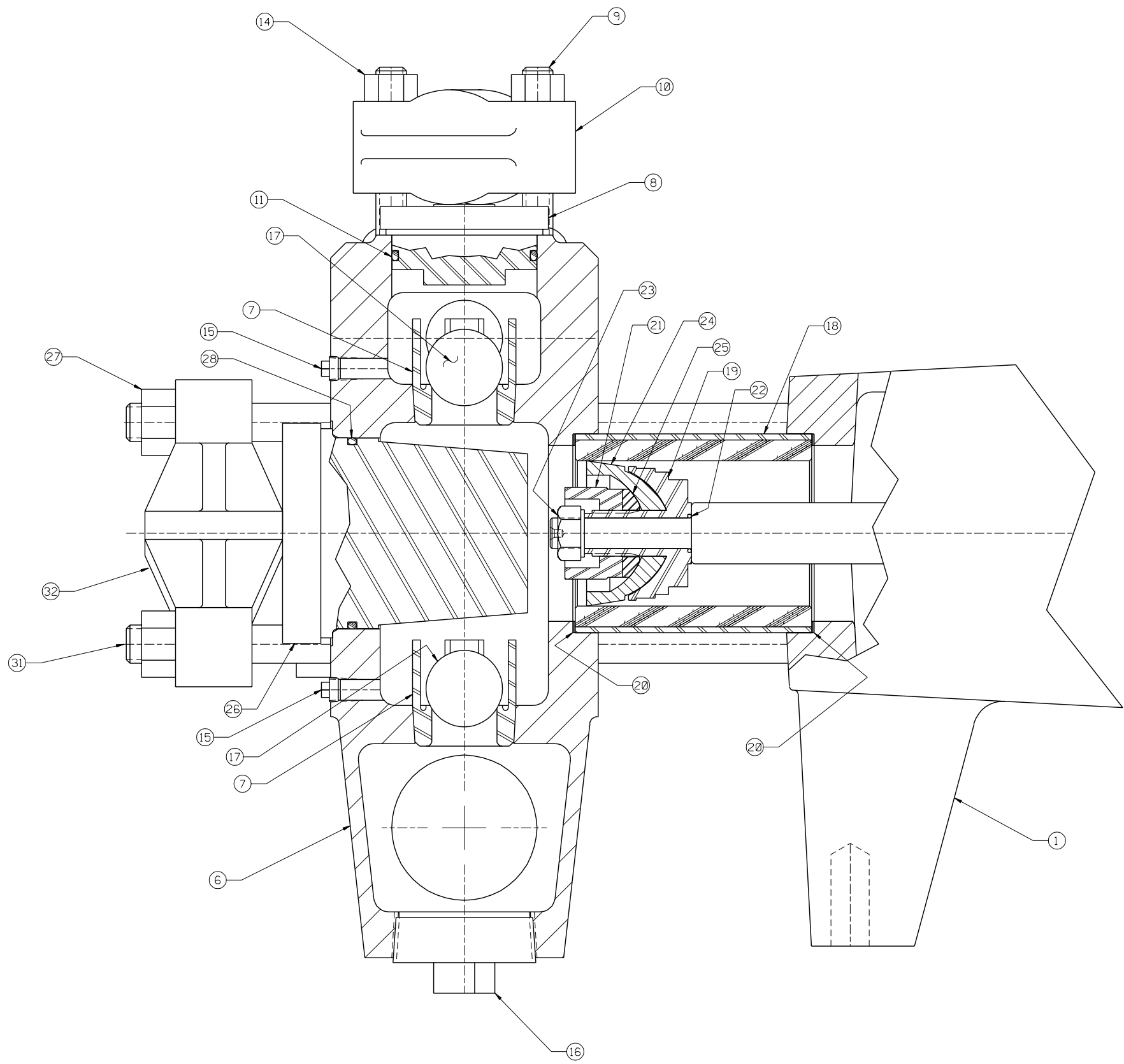

ITEM	NO. RECD	PART NO.	PART NAME
①	1	5271955	POWER END ASSEMBLY:
②	1	5268120	FLUID CYLINDER ASSEMBLY:
③	3	5268133	CYLINDER/PISTON GROUP:
④	1	5268138	ATTACHING GROUP:
⑤	1	5268145	CARTON/MANUAL GROUP:
* ⑥	1	5257262	FLUID CYLINDER:
* ⑦	6	1283896	VALVE SEAT:
* ⑧	3	1283530	VALVE COVER:
* ⑨	6	1248372	STUD: 1/2-13 UNC-2A X 4.0 LG.
* ⑩	3	1247716	VALVE COVER CLAMP:
* ⑪	3	1181154	O-RING: 2 3/8" OD X .125 NOM., BUNA-N
* ⑫	2	1177205	CAPLUG: INT. 44 (NOT SHOWN)
* ⑬	2	1177202	CAPLUG: INT. 17S (NOT SHOWN)
* ⑭	6	1121511	HEX NUT: 1/2-13
* ⑮	4	1109973	PLUG: 1/8" PIPE
* ⑯	3	1105121	PLUG: 2" PIPE
* ⑰	6	1187042	BALL: 1 3/16" DIA, 440 SST
** ⑱	3	1267586	CYLINDER: 2 3/4" ID, CERAMIC
** ⑲	3	A91663	CUP HOLDER:
** ⑳	6	1279676	CYLINDER GASKET:
** ㉑	3	A5016	PLUNGER NUT:
** ㉒	3	1101176	O-RING: 5/8" OD X .063 NOM., BUNA-N
** ㉓	3	8309	SPECIAL HEX NUT: 1/2-13
** ㉔	3	A268N	PISTON: 2 3/4" DIA, FABRIC & NEOPRENE
** ㉕	3	1216753	WASHER:
** ㉖	3	1283531	CYLINDER COVER:
*** ㉗	8	1121513	HEX NUT: 5/8-11
*** ㉘	3	1177476	O-RING: 3 1/8" OD X .125 NOM., BUNA-N
*** ㉙	1	1187039	PETCOCK: (NOT SHOWN)
*** ㉚	2	1248349	STUD: 5/8-11 UNC-2A X 9.50 LG. (NS)
*** ㉛	6	5251859	STUD: 5/8-11 UNC-2A X 12.25 LG.
*** ㉜	3	A80392	CYLINDER HEAD CLAMP:

NOTES:  
 1 TORQUE FASTENERS PER FMC ENGR SPEC AS-22  
 2 TEST PUMP PER FMC ENGR SPEC AS-15  
 3 STAMP NAMEPLATE PER FMC ENGR SPEC AS-21  
 4 PAINT PUMP PER FMC ENGR SPEC CP-20

This drawing is the property of FMC Corporation, and may not be used, reproduced, published, or disclosed to others, without express authorization FMC Corp.

**FMC** FMC Corporation  
 Fluid Control Division  
 2825 W. Washington Box 1377  
 Stephenville, Texas 76481

Unless Otherwise Specified:  
 Remove all burrs & sharp corners .015 R.  
 All diameters concentric unless .001 T.S.  
 Angles ±1/2°  
 .XX ±.015  
 .XXX ±.005  
 Finish 125 RMS  
 All dimensions are in inches

PUMP ASSEMBLY  
 L1122B-1, W/2 1/2" NPT X 1 1/4" NPT FLUID  
 END, FABRIC & NEOPRENE PISTON & 440  
 SST BALL VALVE ASSEMBLIES

L	REV BOM#3 QUANTITY	5000294	JCB	12-13-95	RELEASED FOR PRODUCTION	DRAWN	CHJ	10-20-95	SCALE:	NONE	
K	REVISED & REDRAWN	13847	CHJ	10-18-95	ECN	DATE	CDK.	SL	11-02-95	SIZE	DRAWING NO.
REV	WAS	ECN	BY	DATE	✓	03-22-79	APPD.	RMc	11-14-95	D	1283574

1283574

ITEM	NO. REQD	PART NO.	PART NAME
①	1	5271955	POWER END ASSEMBLY:
②	1	5268120	FLUID CYLINDER ASSEMBLY:
③	3	5268133	CYLINDER/PISTON GROUP:
④	1	5268138	ATTACHING GROUP:
⑤	1	5268145	CARTON/MANUAL GROUP:
* ⑥	1	5257262	FLUID CYLINDER:
* ⑦	6	1283896	VALVE SEAT:
* ⑧	3	1283530	VALVE COVER:
* ⑨	6	1248372	STUD: 1/2-13 UNC-2A X 4.0 LG.
* ⑩	3	1247716	VALVE COVER CLAMP:
* ⑪	3	1181154	O-RING: 2 3/8" OD X .125 NOM., BUNA-N
* ⑫	2	1177205	CAPPLUG: INT. 44 (NOT SHOWN)
* ⑬	2	1177202	CAPPLUG: INT. 17S (NOT SHOWN)
* ⑭	6	1121511	HEX NUT: 1/2-13
* ⑮	4	1109973	PLUG: 1/8" PIPE
* ⑯	3	1105121	PLUG: 2" PIPE
* ⑰	6	1187042	BALL: 1 3/16" DIA, 440 SST
** ⑱	3	1267586	CYLINDER: 2 3/4" ID, CERAMIC
** ⑲	3	A91663	CUP HOLDER:
** ⑳	6	1279676	CYLINDER GASKET:
** ㉑	3	A5016	PLUNGER NUT:
** ㉒	3	1101176	O-RING: 5/8" OD X .063 NOM., BUNA-N
** ㉓	3	8309	SPECIAL HEX NUT: 1/2-13
** ㉔	3	A268N	PISTON: 2 3/4" DIA, FABRIC & NEOPRENE
** ㉕	3	1216753	WASHER:
** ㉖	3	1283531	CYLINDER COVER:
*** ㉗	8	1121513	HEX NUT: 5/8-11
*** ㉘	3	1177476	O-RING: 3 1/8" OD X .125 NOM., BUNA-N
*** ㉙	1	1187039	PETCOCK: (NOT SHOWN)
*** ㉚	2	1248349	STUD: 5/8-11 UNC-2A X 9.50 LG. (NS)
*** ㉛	6	5251859	STUD: 5/8-11 UNC-2A X 12.25 LG.
*** ㉜	3	A80392	CYLINDER HEAD CLAMP:

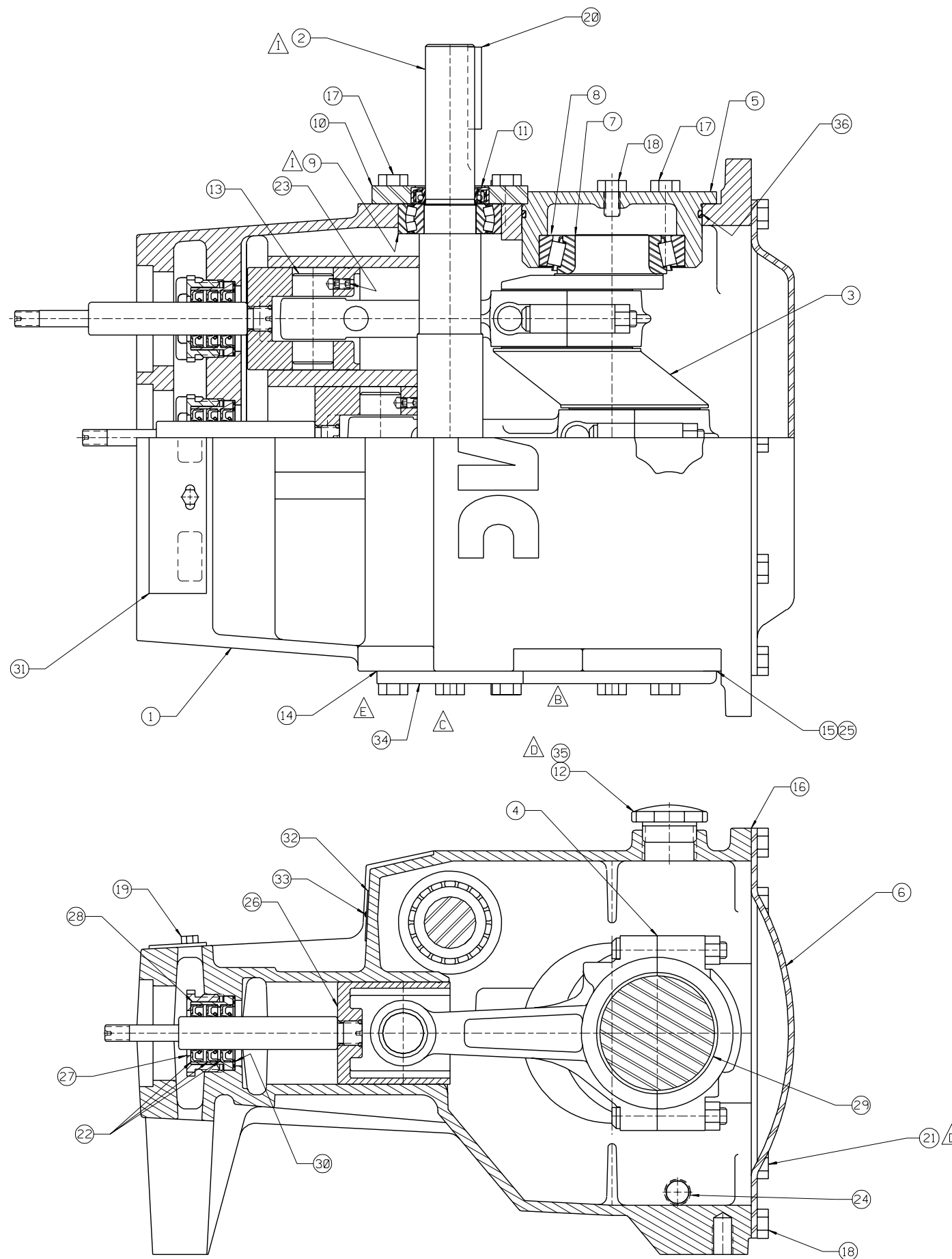

ITEM	NO. RECD	PART NO.	PART NAME
①	1	5257698	POWER FRAME:
②	1	P511596	PINION SHAFT:
③	1	1285094	ECCENTIRC GEAR ASSEMBLY:
④	3	5266814	CONNECTING ROD ASSEMBLY:
⑤	2	1248369	ECCENTRIC BEARING CAP:
⑥	1	P508969	BACKCOVER:
⑦	2	1177473	BEARING CONE: 2.25 ID, TIM #39581
⑧	2	1177474	BEARING CUP: 4.437 OD, TIM #39520
⑨	2	P511746	BEARING: SPHERICAL ROLLER
⑩	1	5257338	PINION BEARING CAP:
⑪	1	5257339	OIL SEAL: PINION SHAFT
⑫	1	A5054	OIL CAP:
⑬	3	A91014	WRIST PIN:
⑭	2	A91674	GASKET: PINION CAP
⑮	2	A91675	GASKET: BEARING CAP
⑯	1	P508966	GASKET: BACKCOVER
⑰	12	1100054	HEX HD. CAP SCREW: 1/2-13 X 1" LG.
⑱	20	1106980	HEX HD. CAP SCREW: 1/2-13 X 3/4" LG.
⑲	2	1100804	HEX HD. CAP SCREW: 1/4-20 X 1/2" LG.
⑳	1	1104349	KEY: 3/8" SQ. X 2 1/2" LG.
㉑	1	3269460	PLUG: PIPE, 1/8" NPT, POLY (NS)
㉒	9	1177489	OIL SEAL: PLUNGER ROD
㉓	6	1182554	SET SCREW: 5/16-18 X 5/16" LG., SOC. HD.
㉔	2	1187048	PLUG: 1/2" PIPE, MAG.
㉕	6	1252595	SHIM:
㉖	3	1252939	CROSSHEAD ASSEMBLY:
㉗	3	1266323	PACKING NUT:
㉘	3	3268369	SEAL HOLDER:
㉙	6	P506675	BEARING: CONNECTING ROD
㉚	3	3268418	GASKET: SEAL HOLDER
㉛	1	5260567	INSPECTION PLATE:
㉜	1	5277981	NAMEPLATE:
㉝	2	1187413	SELF-TAPPING SCREW: #4 X 3/16" LG.
㉞	1	P508916	PINION BEARING CAP: CLOSED
㉟	1	3269461	PLUG: PIPE, 1 1/4" NPT, POLY (NS)
㊱	2	3226710	O-RING: 5.50" OD X .12 NOM, BUNA-N

NOTES:  
 1 TORQUE FASTENERS PER FMC ENGR SPEC AS-22  
 ㉑ ㉟ ITEMS 21 AND 35 ARE TO BE INSTALLED AFTER TESTING, AND BEFORE CLEANING AND PAINTING.

I REV BOM & GRAPHICS		5009542	JMW	12-07-00	This drawing is the property of FMC Corporation, and may not be used, reproduced, published, or disclosed to others, without express authorization FMC Corp.	FMC Corporation Fluid Control Division 2825 W. Washington Box 1377 Stephenville, Texas 76481
H REV BOM ITEM 29		5004584	SJK	05-17-00		
G REV BOM		5004403	BKM	03-08-00	Unless Otherwise Specified: Remove all burrs & sharp corners .005 R. All diameters concentric unless .001 I.D. Angles ±1/2° .XX ±.015 .XXX ±.005 Finish 125 RMS All dimensions are in inches	POWER END ASSEMBLY F/L11, LH
F REV BOM		5009597	BKM	06-24-99		
E REV BOM		5003413	BKM	05-05-99		
D REVISE BOM		5003383	BKM	09-22-97		
C REVISE BOM		13847	CHJ	10-17-95		
B REV CASE GRAPHICS		12529	SJK	01-13-94	RELEASED FOR PRODUCTION	DRAWN CHJ 10-21-94 SCALE: NONE CKD. SL 10-27-94 SIZE DRAWING NO. APPD. RMC 10-29-94
A REVISED & DIGITIZED		12261	CHJ	10-21-94	ECN DATE	5271955
REV WAS		ECN	BY	DATE	✓	✓

5271955

	ITEM	NO. REQD	PART NO.	PART NAME
	①	1	5257698	POWER FRAME:
△	②	1	P511596	PINION SHAFT:
	③	1	1285094	ECCENTIRC GEAR ASSEMBLY:
	④	3	5266814	CONNECTING ROD ASSEMBLY:
	⑤	2	1248369	ECCENTRIC BEARING CAP:
△	⑥	1	P508969	BACKCOVER:
	⑦	2	1177473	BEARING CONE: 2.25 ID, TIM #39581
	⑧	2	1177474	BEARING CUP: 4.437 OD, TIM #39520
△	⑨	2	P511746	BEARING: SPHERICAL ROLLER
	⑩	1	5257338	PINION BEARING CAP:
	⑪	1	5257339	OIL SEAL: PINION SHAFT
	⑫	1	A5054	OIL CAP:
	⑬	3	A91014	WRIST PIN:
	⑭	2	A91674	GASKET: PINION CAP
	⑮	2	A91675	GASKET: BEARING CAP
△	⑯	1	P508966	GASKET: BACKCOVER
△	⑰	12	1100054	HEX HD. CAP SCREW: 1/2-13 X 1" LG.
△	⑱	20	1106980	HEX HD. CAP SCREW: 1/2-13 X 3/4" LG.
	⑲	2	1100804	HEX HD. CAP SCREW: 1/4-20 X 1/2" LG.
	⑳	1	1104349	KEY: 3/8" SQ. X 2 1/2" LG.
△	㉑	1	3269460	PLUG: PIPE, 1/8" NPT, POLY (NS)
△	㉒	9	1177489	OIL SEAL: PLUNGER ROD
	㉓	6	1182554	SET SCREW: 5/16-18 X 5/16" LG., SOC. HD.
	㉔	2	1187048	PLUG: 1/2" PIPE, MAG.
	㉕	6	1252595	SHIM:
	㉖	3	1252939	CROSSHEAD ASSEMBLY:
	㉗	3	1266323	PACKING NUT:
△	㉘	3	3268369	SEAL HOLDER:
△	㉙	6	P506675	BEARING: CONNECTING ROD
△	㉚	3	3268418	GASKET: SEAL HOLDER
	㉛	1	5260567	INSPECTION PLATE:
	㉜	1	5277981	NAMEPLATE:
	㉝	2	1187413	SELF-TAPPING SCREW: #4 X 3/16" LG.
△	㉞	1	P508916	PINION BEARING CAP: CLOSED
△	㉟	1	3269461	PLUG: PIPE, 1/4" NPT, POLY (NS)
△	㊱	2	3226710	O-RING: 5.50" OD X .12 NOM, BUNA-N

NOTES:

1 TORQUE FASTENERS PER FMC ENGR SPEC AS-22

△ 2 ITEMS 21 AND 35 ARE TO BE INSTALLED AFTER TESTING, AND BEFORE CLEANING AND PAINTING.