

\* THESE COMPONENTS ARE LOCATED IN THE FLUID CYLINDER ASSEMBLY, ITEM ②  
 \*\* THESE COMPONENTS ARE LOCATED IN THE CYLINDER/PISTON GROUP, ITEM ③  
 \*\*\* THESE COMPONENTS ARE LOCATED IN THE ATTACHING GROUP, ITEM ④

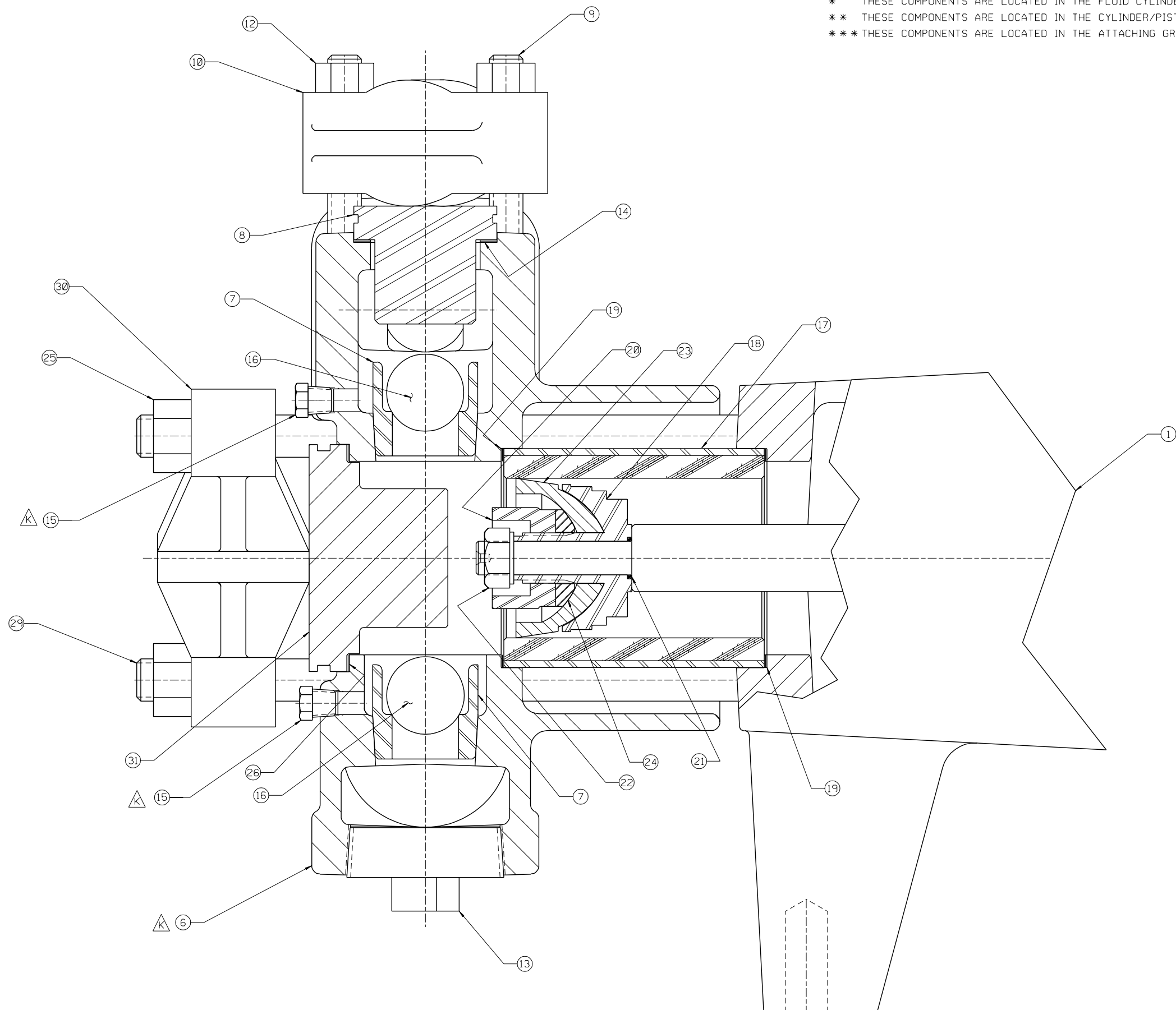

ITEM	NO. REQD	PART NO.	PART NAME
①	1	5271955	POWER END ASSEMBLY:
②	1	5268126	FLUID CYLINDER ASSEMBLY:
③	1	5268131	CYLINDER/PISTON GROUP:
④	1	5268142	ATTACHING GROUP:
⑤	1	5266226	CARTON/MANUAL GROUP:
⑥	1	1284777	FLUID CYLINDER:
⑦	6	1284740	VALVE SEAT:
⑧	3	1285113	VALVE COVER:
⑨	6	A5076	STUD: 1/2-13 UNC-2A X 3.25 LG.
⑩	3	A80391	VALVE COVER CLAMP:
⑪	2	1177202	CAPLUG: INT. 17S (NOT SHOWN)
⑫	6	1121511	HEX NUT: 1/2-13
⑬	3	1105121	PLUG: 2" PIPE
⑭	3	1279675	VALVE COVER GASKET:
⑮	6	P501267	PLUG: 1/8" PIPE
⑯	6	1101419	BALL: 1 1/8" DIA, 440 SST GR-100
⑰	3	1257452	CYLINDER: 2 1/4" ID, CERAMIC
⑱	3	1278125	CUP HOLDER:
⑲	6	1279676	CYLINDER GASKET:
⑳	3	A5016	PLUNGER NUT:
㉑	3	1101176	O-RING: 5/8" OD X .063 NOM., BUNA-N
㉒	3	8309	SPECIAL HEX NUT: 1/2-13
㉓	3	A3434N	PISTON: 2 1/4" DIA, NEOPRENE & FABRIC
㉔	3	1207289	WASHER:
㉕	8	1121513	HEX NUT: 5/8-11
㉖	3	1279674	CYLINDER COVER GASKET:
㉗	1	1187039	PETCOCK: (NOT SHOWN)
㉘	2	A91672	STUD: 5/8-11 UNC-2A X 7.88 LG. (NS)
㉙	6	1279602	STUD: 5/8-11 UNC-2A X 10.00 LG.
㉚	3	A80392	CYLINDER HEAD CLAMP:
㉛	3	1285112	CYLINDER COVER:

NOTES:  
 1 TORQUE FASTENERS PER FMC ENGR SPEC AS-22  
 2 TEST PUMP PER FMC ENGR SPEC AS-15  
 3 STAMP NAMEPLATE PER FMC ENGR SPEC AS-21  
 4 PAINT PUMP PER FMC ENGR SPEC CP-20

This drawing is the property of FMC Corporation, and may not be used, reproduced, published, or disclosed to others, without express authorization FMC Corp.		FMC Corporation Fluid Control Division 2825 W. Washington Box 1377 Stephenville, Texas 76481	
Unless Otherwise Specified: Remove all burrs & sharp corners .015 R. All diameters concentric unless .001 TDC.		PUMP ASSEMBLY W1118B, W/2" NPT X 1 1/4" NPT FLUID END, NEOPRENE & FABRIC PISTON & 440 SST BALL VALVE ASSEMBLIES	
Angles ±1/2° .X ±.015 .XX ±.015 .XXX ±.005 Finish 125 RMS All dimensions are in inches		RELEASED FOR PRODUCTION ECN DATE	
K NEW PLUGS 5002294 PJG 06-10-98 J REVISED & REDRAWN 13847 CHJ 11-09-95 REV WAS ECN BY DATE		DRAWN CHJ 10-18-95 SCALE: NONE CKD. SL 11-01-95 SIZE DRAWING NO. APPD. RMC 12-08-95 D 1284741	

1284741

ITEM	NO. REQD	PART NO.	PART NAME
ITEM (2)			
M (3)			
(1)	1	5271955	POWER END ASSEMBLY:
(2)	1	5268126	FLUID CYLINDER ASSEMBLY:
(3)	1	5268131	CYLINDER/PISTON GROUP:
(4)	1	5268142	ATTACHING GROUP:
(5)	1	5266226	CARTON/MANUAL GROUP:
(6)	1	1284777	FLUID CYLINDER:
(7)	6	1284740	VALVE SEAT:
(8)	3	1285113	VALVE COVER:
(9)	6	A5076	STUD: 1/2-13 UNC-2A X 3.25 LG.
(10)	3	A80391	VALVE COVER CLAMP:
(11)	2	1177202	CAPLUG: INT. 17S (NOT SHOWN)
(12)	6	1121511	HEX NUT: 1/2-13
(13)	3	1105121	PLUG: 2" PIPE
(14)	3	1279675	VALVE COVER GASKET:
(15)	6	P501267	PLUG: 1/8" PIPE
(16)	6	1101419	BALL: 1 1/8" DIA, 440 SST GR-100
(17)	3	1257452	CYLINDER: 2 1/4" ID, CERAMIC
(18)	3	1278125	CUP HOLDER:
(19)	6	1279676	CYLINDER GASKET:
(20)	3	A5016	PLUNGER NUT:
(21)	3	1101176	O-RING: 5/8" OD X .063 NOM., BUNA-N
(22)	3	8309	SPECIAL HEX NUT: 1/2-13
(23)	3	A3434N	PISTON: 2 1/4" DIA, NEOPRENE & FABRIC
(24)	3	1207289	WASHER:
(25)	8	1121513	HEX NUT: 5/8-11
(26)	3	1279674	CYLINDER COVER GASKET:
(27)	1	1187039	PETCOCK: (NOT SHOWN)
(28)	2	A91672	STUD: 5/8-11 UNC-2A X 7.88 LG. (NS)
(29)	6	1279602	STUD: 5/8-11 UNC-2A X 10.00 LG.
(30)	3	A80392	CYLINDER HEAD CLAMP:
(31)	3	1285112	CYLINDER COVER:

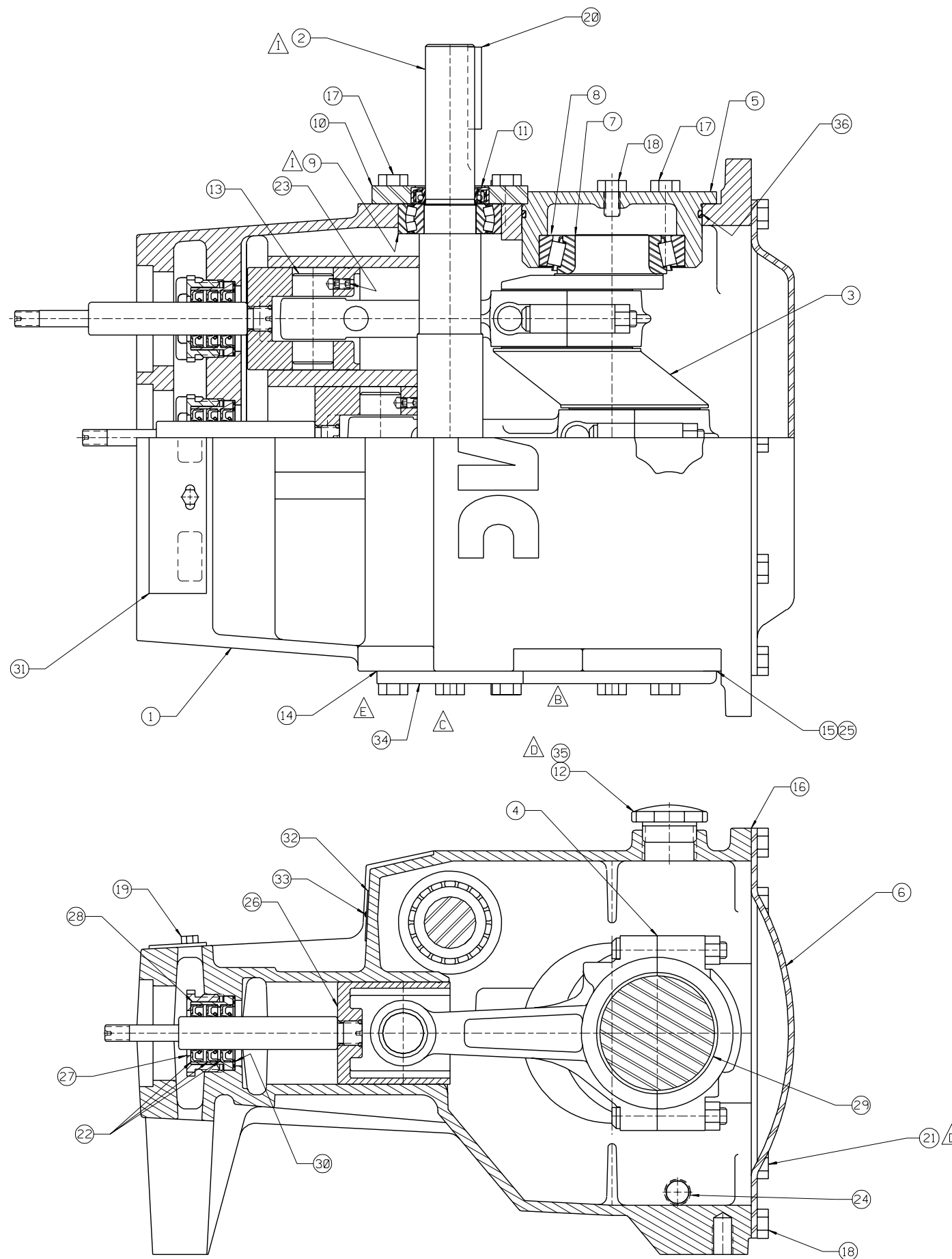

ITEM	NO. RECD	PART NO.	PART NAME
①	1	5257698	POWER FRAME:
②	1	P511596	PINION SHAFT:
③	1	1285094	ECCENTIRC GEAR ASSEMBLY:
④	3	5266814	CONNECTING ROD ASSEMBLY:
⑤	2	1248369	ECCENTRIC BEARING CAP:
⑥	1	P508969	BACKCOVER:
⑦	2	1177473	BEARING CONE: 2.25 ID, TIM #39581
⑧	2	1177474	BEARING CUP: 4.437 OD, TIM #39520
⑨	2	P511746	BEARING: SPHERICAL ROLLER
⑩	1	5257338	PINION BEARING CAP:
⑪	1	5257339	OIL SEAL: PINION SHAFT
⑫	1	A5054	OIL CAP:
⑬	3	A91014	WRIST PIN:
⑭	2	A91674	GASKET: PINION CAP
⑮	2	A91675	GASKET: BEARING CAP
⑯	1	P508966	GASKET: BACKCOVER
⑰	12	1100054	HEX HD. CAP SCREW: 1/2-13 X 1" LG.
⑱	20	1106980	HEX HD. CAP SCREW: 1/2-13 X 3/4" LG.
⑲	2	1100804	HEX HD. CAP SCREW: 1/4-20 X 1/2" LG.
⑳	1	1104349	KEY: 3/8" SQ. X 2 1/2" LG.
㉑	1	3269460	PLUG: PIPE, 1/8" NPT, POLY (NS)
㉒	9	1177489	OIL SEAL: PLUNGER ROD
㉓	6	1182554	SET SCREW: 5/16-18 X 5/16" LG., SOC. HD.
㉔	2	1187048	PLUG: 1/2" PIPE, MAG.
㉕	6	1252595	SHIM:
㉖	3	1252939	CROSSHEAD ASSEMBLY:
㉗	3	1266323	PACKING NUT:
㉘	3	3268369	SEAL HOLDER:
㉙	6	P506675	BEARING: CONNECTING ROD
㉚	3	3268418	GASKET: SEAL HOLDER
㉛	1	5260567	INSPECTION PLATE:
㉜	1	5277981	NAMEPLATE:
㉝	2	1187413	SELF-TAPPING SCREW: #4 X 3/16" LG.
㉞	1	P508916	PINION BEARING CAP: CLOSED
㉟	1	3269461	PLUG: PIPE, 1 1/4" NPT, POLY (NS)
㊱	2	3226710	O-RING: 5.50" OD X .12 NOM, BUNA-N

NOTES:  
 1 TORQUE FASTENERS PER FMC ENGR SPEC AS-22  
 ㉑ ㉟ ITEMS 21 AND 35 ARE TO BE INSTALLED AFTER TESTING, AND BEFORE CLEANING AND PAINTING.

I REV BOM & GRAPHICS		5009542	JMW	12-07-00	This drawing is the property of FMC Corporation, and may not be used, reproduced, published, or disclosed to others, without express authorization FMC Corp.	FMC Corporation Fluid Control Division 2825 W. Washington Box 1377 Stephenville, Texas 76481
H REV BOM ITEM 29		5004584	SJK	05-17-00		
G REV BOM		5004403	BKM	03-08-00	Unless Otherwise Specified: Remove all burrs & sharp corners .005 R. All diameters concentric unless .001 I.D. Angles ±1/2° .XX ±.015 .XXX ±.005 Finish 125 RMS All dimensions are in inches	POWER END ASSEMBLY F/L11, LH
F REV BOM		5009597	BKM	06-24-99		
E REV BOM		5003413	BKM	05-05-99		
D REVISE BOM		5003383	BKM	09-22-97		
C REVISE BOM		13847	CHJ	10-17-95	RELEASED FOR PRODUCTION ECN DATE	DRAWN CHJ 10-21-94 SCALE: NONE CKD. SL 10-27-94 SIZE DRAWING NO. APPD. RMC 10-29-94 D 5271955
B REV CASE GRAPHICS		12529	SJK	01-13-94		
A REVISED & DIGITIZED		12261	CHJ	10-21-94	REV WAS ECN BY DATE	5271955
REV WAS		ECN	BY	DATE		

	ITEM	NO. REQD	PART NO.	PART NAME
	①	1	5257698	POWER FRAME:
△	②	1	P511596	PINION SHAFT:
	③	1	1285094	ECCENTIRC GEAR ASSEMBLY:
	④	3	5266814	CONNECTING ROD ASSEMBLY:
	⑤	2	1248369	ECCENTRIC BEARING CAP:
△	⑥	1	P508969	BACKCOVER:
	⑦	2	1177473	BEARING CONE: 2.25 ID, TIM #39581
	⑧	2	1177474	BEARING CUP: 4.437 OD, TIM #39520
△	⑨	2	P511746	BEARING: SPHERICAL ROLLER
	⑩	1	5257338	PINION BEARING CAP:
	⑪	1	5257339	OIL SEAL: PINION SHAFT
	⑫	1	A5054	OIL CAP:
	⑬	3	A91014	WRIST PIN:
	⑭	2	A91674	GASKET: PINION CAP
	⑮	2	A91675	GASKET: BEARING CAP
△	⑯	1	P508966	GASKET: BACKCOVER
△	⑰	12	1100054	HEX HD. CAP SCREW: 1/2-13 X 1" LG.
△	⑱	20	1106980	HEX HD. CAP SCREW: 1/2-13 X 3/4" LG.
	⑲	2	1100804	HEX HD. CAP SCREW: 1/4-20 X 1/2" LG.
	⑳	1	1104349	KEY: 3/8" SQ. X 2 1/2" LG.
△	㉑	1	3269460	PLUG: PIPE, 1/8" NPT, POLY (NS)
△	㉒	9	1177489	OIL SEAL: PLUNGER ROD
	㉓	6	1182554	SET SCREW: 5/16-18 X 5/16" LG., SOC. HD.
	㉔	2	1187048	PLUG: 1/2" PIPE, MAG.
	㉕	6	1252595	SHIM:
	㉖	3	1252939	CROSSHEAD ASSEMBLY:
	㉗	3	1266323	PACKING NUT:
△	㉘	3	3268369	SEAL HOLDER:
△	㉙	6	P506675	BEARING: CONNECTING ROD
△	㉚	3	3268418	GASKET: SEAL HOLDER
	㉛	1	5260567	INSPECTION PLATE:
	㉜	1	5277981	NAMEPLATE:
	㉝	2	1187413	SELF-TAPPING SCREW: #4 X 3/16" LG.
△	㉞	1	P508916	PINION BEARING CAP: CLOSED
△	㉟	1	3269461	PLUG: PIPE, 1/4" NPT, POLY (NS)
△	㊱	2	3226710	O-RING: 5.50" OD X .12 NOM, BUNA-N

NOTES:

1 TORQUE FASTENERS PER FMC ENGR SPEC AS-22

△ 2 ITEMS 21 AND 35 ARE TO BE INSTALLED AFTER TESTING, AND BEFORE CLEANING AND PAINTING.