

## Pump data 3.5 BHP

### Model A04-I04

### Piston Pump

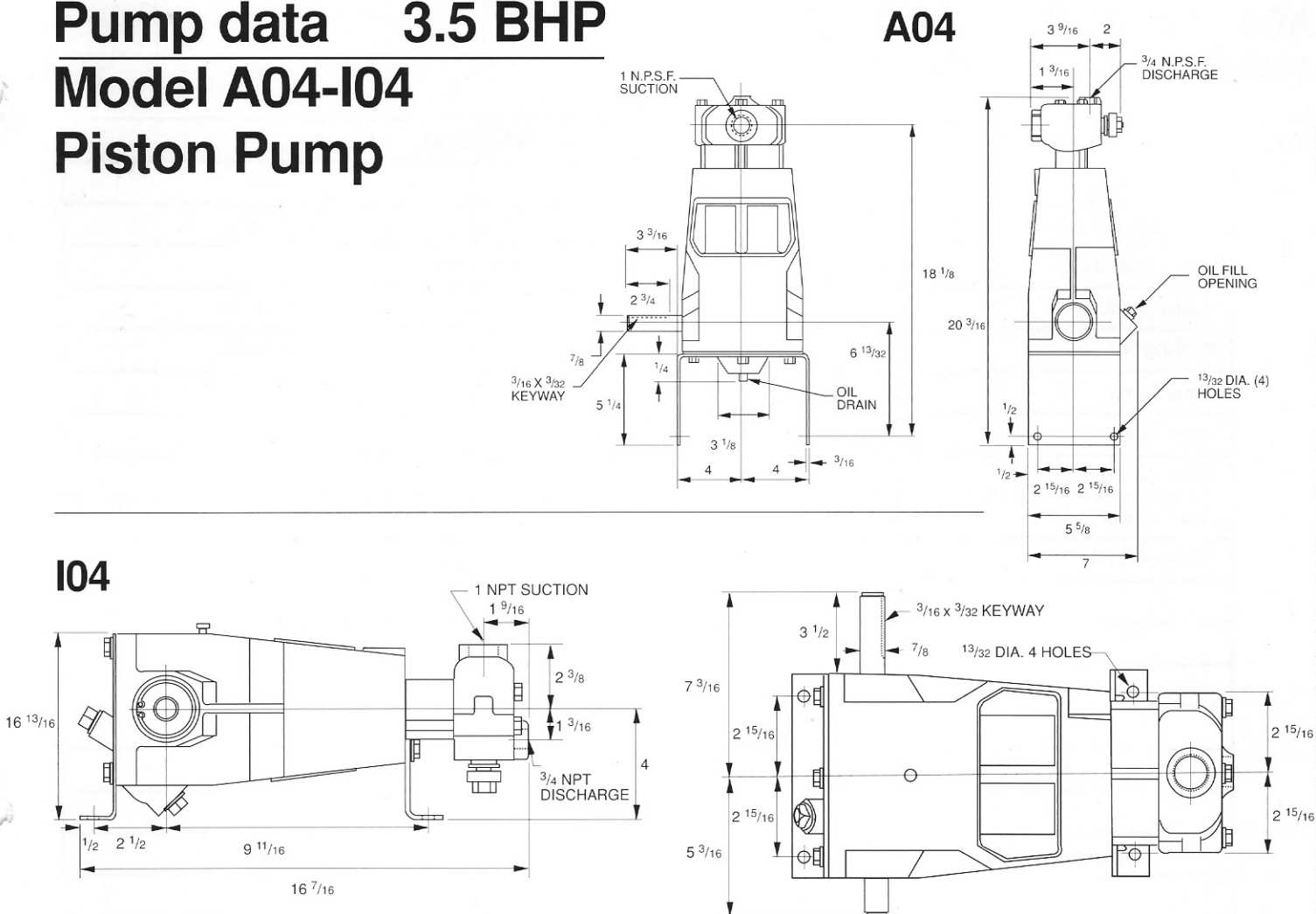

**Pump type:** Duplex piston

### Drive-end specifications

Stroke — 1"

Oil Type — SAE 30

Direction of Rotation — Model A04 — either  
 Model I04 — Top of shaft toward head

Shipping Weight — 43 lbs

Maximum Speed — 500 RPM

Minimum Speed — 306 RPM

No. of Pistons — 2

Crankcase Material — Cast Iron

Oil Capacity — 1 quart

Shaft Extension — Standard Shown

### I04/A04 DUPLEX POWER PUMP

1" , (25.4 mm) STROKE 1140 lb. (5070N) FRAME (PLUNGER) LOAD

	PISTON DIAMETER		Displacement		Maximum Discharge Pressure		STD VALVE DATA			CYLINDER CONNECTIONS	
	INCH	MM	GAL/REV	L/REV	PSIG	BAR	DISC. DIAMETER	SEAT HOLE AREA	% Area	SUCTION	DISCHARGE
<b>A</b>	410	1.25	31.8	.0106	.040	750	.97" (24.6 mm)	.442 IN <sup>2</sup> (285 mm <sup>2</sup> )	36	1 NPT	3/4" NPT
	411	1.375	34.9	.0129	.049	600			30		
	413	1.625	41.3	.0180	.068	550			21		

