

Pump data 18 BHP

Model LO6

Piston Pump

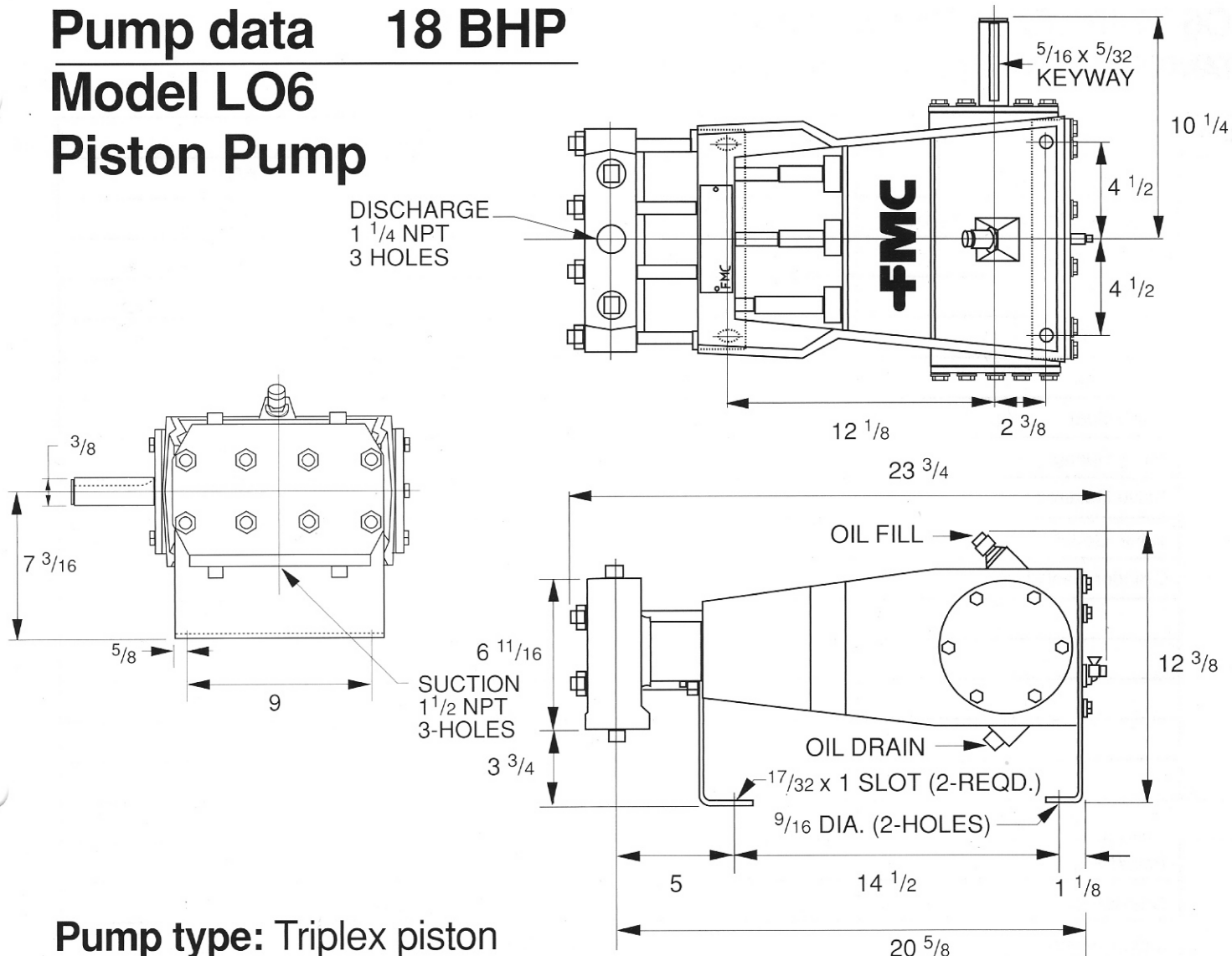

Pump type: Triplex piston

Drive-end specifications

Stroke — 1 1/2"

Oil Type — SAE 30

Oil Capacity — 2 quart

Direction of Rotation — Top of shaft toward head

Shipping Weight — 175 lbs

Maximum Speed — 475 RPM

Minimum Speed — 100 RPM

No. of Pistons — 3

Crankcase Material — Cast Iron

Shaft Extension — Standard Shown,

R.H. shaft and double-shaft optional

LO6 TRIPLEX POWER PUMP

1 1/2", (38.1 mm) STROKE 2785 lb. (12400N) FRAME (PLUNGER) LOAD

	PISTON DIAMETER		Displacement		Maximum Discharge Pressure		STD VALVE DATA			CYLINDER CONNECTIONS		
	INCH	MM	GAL/REV	L/REV	PSIG	BAR	DISC. DIAMETER	SEAT HOLE AREA	% Area	SUCTION	DISCHARGE	
A	614	1.75	44.5	.0469	.18	1000	68.9	1.14" (29 mm)	.69 IN ² (445 mm ²)	29	1 1/2" NPT	1 1/4" NPT
	618	2.25	57.2	.0775	.29	700	48.2			17		

