

Pump data 51.7 BHP

Model L11 Piston Pump

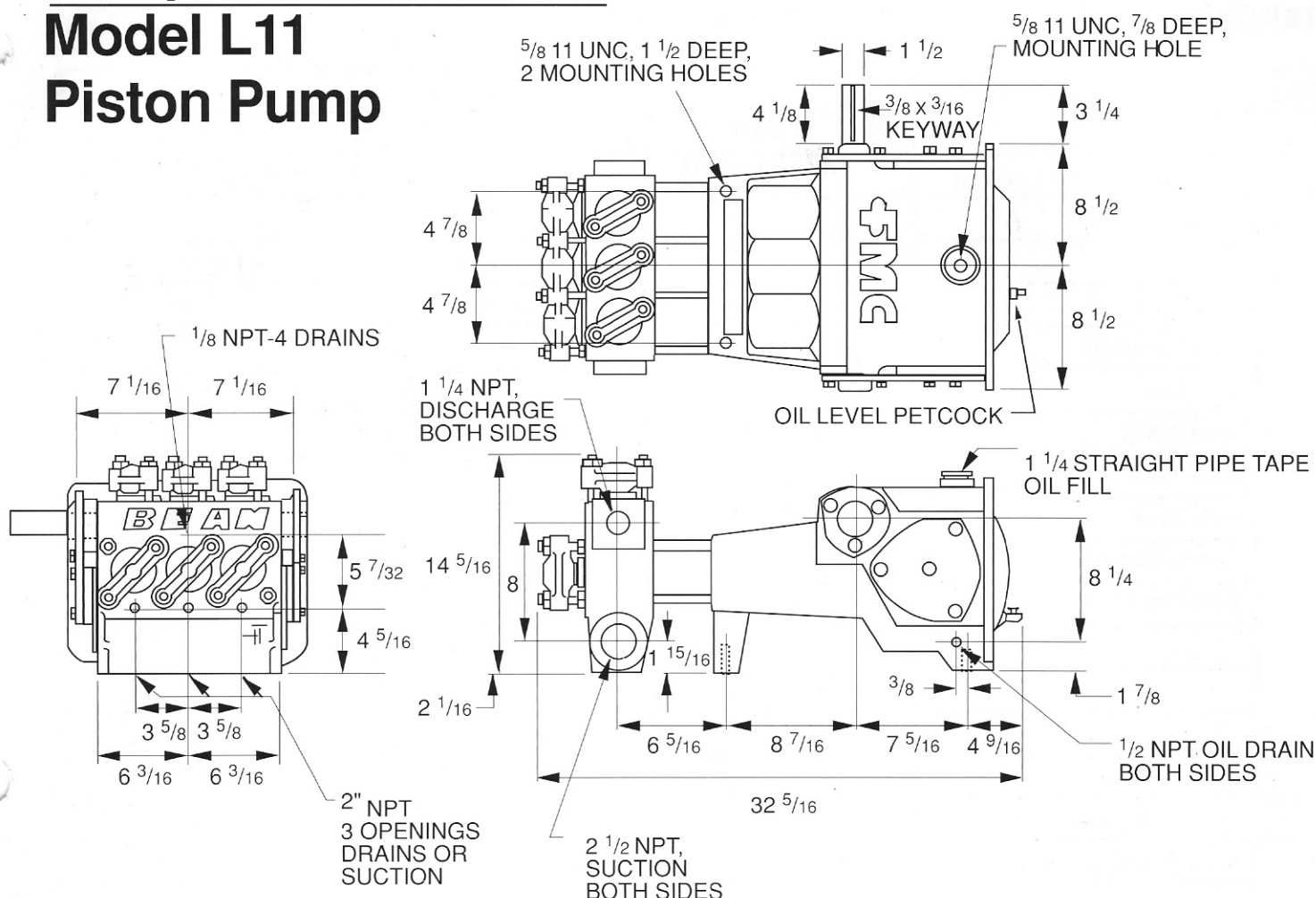

Pump type: Triplex piston

Drive-end specifications

Stroke — 2 3/4"
 Internal Gear Reduction Ratio — 3.6:1
 Oil Type — SAE 30
 Direction of Rotation — Top of shaft away from fluid end
 Shipping Weight — 460 lbs

Maximum Speed — SEE BACK
 Minimum Speed — SEE BACK
 No. of Pistons — 3
 Crankcase Material — Cast Iron
 Oil Capacity — 1 gallon
 Shaft Extension — LH Standard
 RH shaft and double-ended shaft optional

L11 TRIPLEX POWER PUMP

2 3/4" , (69.9 mm) STROKE 6000 lb. (26700N) FRAME (PLUNGER) LOAD

	PISTON DIAMETER		Displacement		Maximum Discharge Pressure		STD VALVE DATA			CYLINDER CONNECTIONS		
	INCH	MM	GAL/REV	L/REV	PSIG	BAR	DISC. DIAMETER	SEAT HOLE AREA	% Area	SUCTION	DISCHARGE	
A	1118	2.25	57.15	.0394	.149	1200	82.8	1.450" (36.8 mm)	1.21 IN ² (779 mm ²)	30	2 1/2 NPT	1 1/4" NPT
	1122	2.75	69.85	.0589	.223	1000	69.0			20		

Displacement based on input RPM

